



Solution Brief



How You'll Benefit From a Phased Modernization

Industrial automation systems are tough, but at some point like most equipment they do need to be replaced by a more modern setup. That new system is a great prospect – updated technology, and potentially more opportunities for facility-wide communications to make the most of your equipment's data. The downside to all of that may surface when you start to wonder just how you'll be making that switch from a legacy to a modern control system. Programs that need to be transferred over ... production that will cease ... testing to make sure your operation has been switched over correctly ...

Before you start thinking a less costly option would be to stick it out with your legacy system till the bitter end, you should know that there is a lower-risk alternative to a standard rip-and-replace. By *modernizing in phases*, you can update your facility on a timeline that works for you and your production needs – and not the other way around. Using phased modernization solutions, you can:

- Transfer your original PLC code from your legacy Remote I/O™ or DH+™-based PLC to your new EtherNet/IP™ controller.
- Retain existing I/O until at least the point where you can ensure that your new control system is in place and working well with the other equipment in your facility.
- Reduce the downtime associated with a rip-and-replace – and the lost profits it would likely lead to.

With ProSoft Technology's Modernization Gateway, you can update your:

Variable Frequency Drives

With ProSoft's AN-X2-AB-DHRIO gateway you can upgrade your Remote I/O drives to new PowerFlex® EtherNet/IP™ drives, with no changes to your PLC program. One gateway can support up to 4 drives.

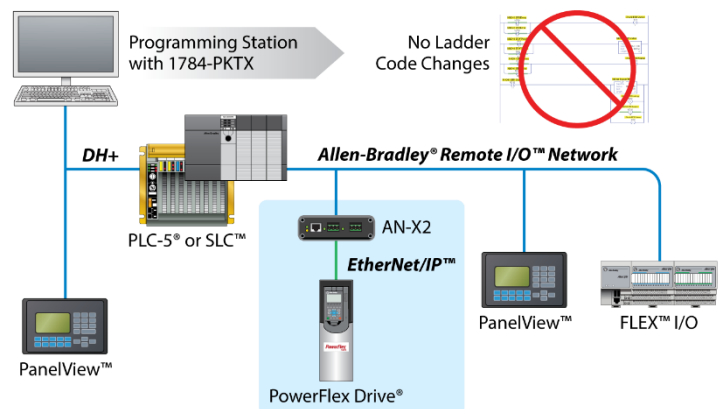

PanelView™ terminals

Are your PanelView terminals or Programming Stations ready for an upgrade? With the AN-X2-AB-DHRIO gateway, you can upgrade your Remote I/O™ and DH+™ PanelViews to new EtherNet/IP PanelView Plus terminals with no changes to your PLC program. One gateway can support up to 8 PanelView terminals.

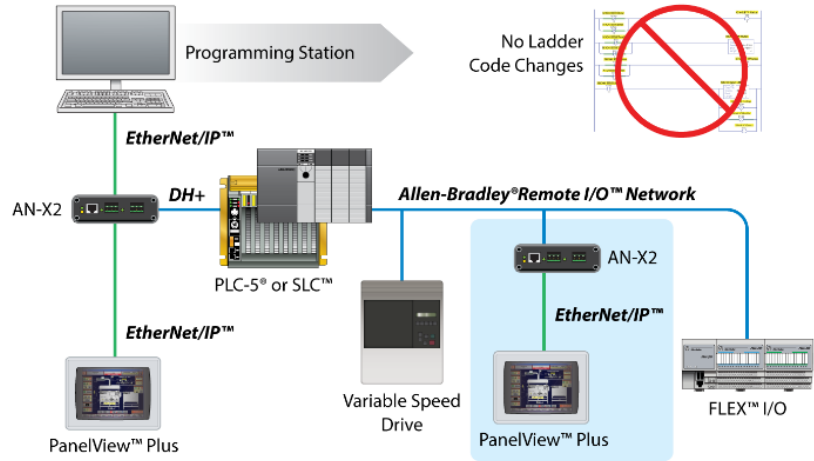

FLEX™ I/O Adapters

With the AN-X2-AB-DHRIO gateway, you can upgrade your Remote I/O adapters for FLEX I/O to new EtherNet/IP adapters. One gateway can support up to 16 connections.

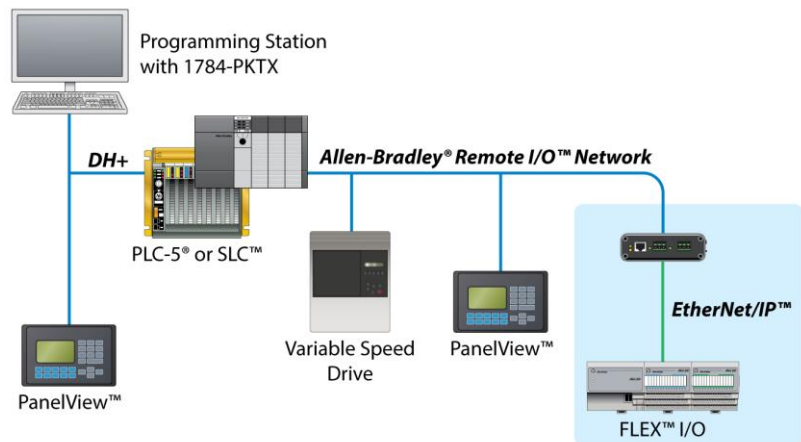

PLC-5[®] or SLC™

Your CompactLogix™ can control your existing Remote I/O devices using the AN-X2-AB-DHRIO gateway. The gateway supports up to 32 racks of I/O. The programming station would need to switch to Ethernet and the DH+™ PanelView would need to be upgraded at the same time as the controller upgrade.

