

inRAx



MVI71-DNP

PLC Platform

DNP 3.0 Master/Slave Communication
Module

User Manual

August 23, 2007

ProSoft
TECHNOLOGY

Please Read This Notice

Successful application of this module requires a reasonable working knowledge of the PLC hardware, the MVI71-DNP Module and the application in which the combination is to be used. For this reason, it is important that those responsible for implementation satisfy themselves that the combination will meet the needs of the application without exposing personnel or equipment to unsafe or inappropriate working conditions.

This manual is provided to assist the user. Every attempt has been made to assure that the information provided is accurate and a true reflection of the product's installation requirements. In order to assure a complete understanding of the operation of the product, the user should read all applicable documentation on the operation of the hardware.

Under no conditions will ProSoft Technology be responsible or liable for indirect or consequential damages resulting from the use or application of the product.

Reproduction of the contents of this manual, in whole or in part, without written permission from ProSoft Technology is prohibited.

Information in this manual is subject to change without notice and does not represent a commitment on the part of ProSoft Technology. Improvements and/or changes in this manual or the product may be made at any time. These changes will be made periodically to correct technical inaccuracies or typographical errors.

Warning: This module is not hot-swappable! Always remove power from the rack before inserting or removing this module, or damage may result to the module, the processor, or other connected devices.

Power, Input, and Output (I/O) wiring must be in accordance with Class 1, Division 2 wiring methods, Article 501-4 (b) of the National Electrical Code, NFPA 70 for installation in the U.S., or as specified in Section 18-1J2 of the Canadian Electrical Code for installations in Canada, and in accordance with the authority having jurisdiction.

- A** Warning – Explosion Hazard – Substitution of components may impair suitability for Class 1, Division 2.
- B** Warning – Explosion Hazard – When in hazardous locations, turn off power before replacing or wiring modules.
- C** Warning – Explosion Hazard – Do not disconnect equipment unless power has been switched off or the area is known to be non-hazardous.

Your Feedback Please

We always want you to feel that you made the right decision to use our products. If you have suggestions, comments, compliments or complaints about the product, documentation or support, please write or call us.

ProSoft Technology

1675 Chester Avenue, Fourth Floor

Bakersfield, CA 93301

+1 (661) 716-5100

+1 (661) 716-5101 (Fax)

<http://www.prosoft-technology.com>

Copyright © ProSoft Technology, Inc. 2000 - 2007. All Rights Reserved.

MVI71-DNP User Manual

August 23, 2007

PSFT.DNP.MVI71.UM.07.08.23

ProSoft Technology®, ProLinX®, inRAx®, ProTalk® and RadioLinX® are Registered Trademarks of ProSoft Technology, Inc.

Contents

PLEASE READ THIS NOTICE	2
Your Feedback Please	3
GUIDE TO THE MVI71-DNP USER MANUAL	9
1 START HERE	11
1.1 System Requirements.....	11
1.2 Package Contents	12
1.3 Setting Jumpers.....	13
1.4 Install the Module in the Rack.....	13
1.5 Connect your PC to the Processor	15
1.6 Download the Sample Program to the Processor	16
1.6.1 Configuring RSLinx	17
1.7 Connect your PC to the Module.....	19
2 INSTALLING AND CONFIGURING THE MODULE	21
2.1 Module Data	23
2.1.1 Status Data	23
2.1.2 User Data	25
2.2 Configuration File.....	26
2.2.1 [Module]	27
2.2.2 [DNP Slave].....	27
2.2.3 [DNP Slave Database]	34
2.2.4 [DNP Slave Binary Inputs].....	36
2.2.5 [DNP Slave Analog Inputs].....	36
2.2.6 [DNP Slave Float Inputs].....	37
2.2.7 [Secondary Port].....	37
2.2.8 [DNP Master].....	39
2.2.9 [IED Database]	40
2.2.10 [DNP Master Slave List]	41
2.2.11 [DNP Master Commands]	41
2.2.12 Slave List.....	46
2.2.13 Command List	47
2.3 Uploading and Downloading the Configuration File	50
2.3.1 Transferring the Configuration File to Your PC.....	50
2.3.2 Transferring the Configuration File to the Module	52
3 LADDER LOGIC	57
4 DIAGNOSTICS AND TROUBLESHOOTING	59
4.1 Reading Status Data From the Module.....	59
4.1.1 The Configuration/Debug Menu	59
4.1.2 Required Hardware	60
4.1.3 Required Software.....	61
4.1.4 Using the Configuration/Debug Port.....	61
4.1.5 Main Menu	62
4.1.6 The Class Assignment Menu	65
4.1.7 DNP Database View Menu.....	67
4.1.8 Master Command List Menu	70
4.1.9 Master Command Error List Menu	71

4.2	LED Status Indicators	72
4.3	Clearing a Fault Condition	72
4.4	Troubleshooting	73
5	REFERENCE	75
5.1	Product Specifications	75
5.1.1	Features and Benefits	76
5.1.2	General Specifications	76
5.1.3	Hardware Specifications	76
5.1.4	Functional Specifications	77
5.2	Functional Overview	78
5.2.1	General Concepts	78
5.2.2	Data Flow Between MVI71-DNP Module and PLC Processor	91
5.3	Designing the system	94
5.3.1	System Design Considerations	94
5.3.2	Data Requirements	95
5.4	Cable Connections	111
5.4.1	RS-232 Configuration/Debug Port.....	111
5.4.2	RS-232	113
5.4.3	RS-422	115
5.4.4	RS-485	116
5.4.5	DB9 to RJ45 Adaptor (Cable 14).....	116
5.5	Collision Avoidance (DNP modules only)	117
5.6	Block Assignments	118
5.6.1	PLC Program Block Assignments vs. File:Offset	118
5.7	DNP Configuration Forms.....	121
5.7.1	DNP User File Configuration.....	121
5.8	MVI71-DNP Communication Module Configuration.....	124
5.9	Error Status Table.....	132
5.10	Module Error Codes.....	136
5.10.1	Slave Port Communication Errors	136
5.10.2	System Configuration Errors	137
5.10.3	DNP Port Configuration Errors	137
5.11	Command Error Codes	138
5.11.1	General Command Errors	138
5.11.2	Application Layer Errors.....	139
5.12	Event Size Computation	140
5.13	Device Profile.....	141
5.14	Slave Unit Device Profile Object Subset.....	142
5.15	Master Unit Device Profile Object Subset.....	150
6	PROSOFT TECHNOLOGY, INC., SUPPORT, SERVICE & WARRANTY	159
6.1	How to Contact Us: Sales and Support	160
6.2	Return Material Authorization (RMA) Policies and Conditions	161
6.2.1	All Product Returns	161
6.3	Procedures for Return of Units Under Warranty	161
6.4	Procedures for Return of Units Out of Warranty	162
6.4.1	Un-repairable Units	162
6.4.2	Purchasing Warranty Extension	163

6.5	LIMITED WARRANTY	163
6.5.1	What Is Covered By This Warranty	163
6.5.2	What Is Not Covered By This Warranty.....	164
6.5.3	DISCLAIMER REGARDING HIGH RISK ACTIVITIES	165
6.5.4	DISCLAIMER OF ALL OTHER WARRANTIES.....	165
6.5.5	LIMITATION OF REMEDIES**	165
6.5.6	Time Limit for Bringing Suit	165
6.5.7	No Other Warranties	166
6.5.8	Intellectual Property.....	166
6.5.9	Additional Restrictions Relating To Software And Other Intellectual Property.....	166
6.5.10	Allocation of risks	166
6.5.11	Controlling Law and Severability	167
INDEX	169

Guide to the MVI71-DNP User Manual

Function		Section to Read	Details
Introduction (Must Do)	→	Start Here (page 21, page 11)	This Section introduces the customer to the module. Included are: package contents, system requirements, hardware installation, and basic configuration.
Verify Communication, Diagnostic and Troubleshooting	→	Verifying Communication (page 59) Diagnostics and Troubleshooting (page 59)	This section describes how to verify communications with the network. Diagnostic and Troubleshooting procedures.
Reference Product Specifications Functional Overview Glossary	→	Reference (page 75) Functional Overview (page 78) Product Specifications (page 75)	These sections contain general references associated with this product, Specifications, and the Functional Overview.
Support, Service, and Warranty Index	→	Support, Service and Warranty (page 159)	This section contains Support, Service and Warranty information. Index of chapters.

1 Start Here

In This Chapter

- System Requirements 11
- Package Contents 12
- Setting Jumpers 13
- Install the Module in the Rack 13
- Connect your PC to the Processor 15
- Download the Sample Program to the Processor 16
- Connect your PC to the Module 19

Installing the MVI71-DNP module requires a reasonable working knowledge of the Rockwell Automation hardware, the MVI71-DNP Module and the application in which they will be used.



Caution: It is important that those responsible for implementation can complete the application without exposing personnel, or equipment, to unsafe or inappropriate working conditions. Safety, quality and experience are key factors in a successful installation.

1.1 System Requirements

The MVI71-DNP module requires the following minimum hardware and software components:

- Rockwell Automation PLC processor, with compatible power supply and one free slot in the rack, for the MVI71-DNP module. The module requires 800mA of available power.
- Rockwell Automation RSLogix 5 programming software.
- Rockwell Automation RSLinx communication software
- Pentium® 100 MHz minimum. Pentium III 700 MHz (or better) recommended
- Supported operating systems:
 - Microsoft Windows XP
 - Microsoft Windows 2000
 - Microsoft Windows NT v4.0 with Service Pack 3 or greater
 - Microsoft Windows ME
 - Microsoft Windows 98
- 64 Mbytes of RAM minimum, 256 Mbytes of RAM recommended

- 100 Mbytes of free hard disk space (or more based on application requirements)
- 256-color VGA graphics adapter, 800 x 600 minimum resolution (True Color 1024 × 768 recommended)
- CD-ROM drive
- 3.5 inch floppy disk drive
- HyperTerminal or other terminal emulator program capable of file transfers using Ymodem protocol.

1.2 Package Contents

The following components are included with your MVI71-DNP module, and are all required for installation and configuration.

Important: Before beginning the installation, please verify that all of the following items are present.

Qty.	Part Name	Part Number	Part Description
1	MVI71-DNP Module	MVI71-DNP	DNP 3.0 Master/Slave Communication Module
1	Cable	RS232 Null Modem	For RS232 Connection to the CFG Port
3	Cable	Cable #14, RJ45 to DB9 Male Adapter	For DB9 Connection to Module's Port
2	Adapter	1454-9F	Two Adapters, DB9 Female to Screw Terminal. For RS422 or RS485 Connections to Port 1 and 2 of the Module
1	ProSoft Solutions CD		Contains sample programs, utilities and documentation for the MVI71-DNP module.

If any of these components are missing, please contact ProSoft Technology Support for replacement parts.

1.3 Setting Jumpers

The following illustration shows the jumper configurations for the various RS interfaces. If you are using an interface other than RS-232 (default), you must change the jumpers as shown:

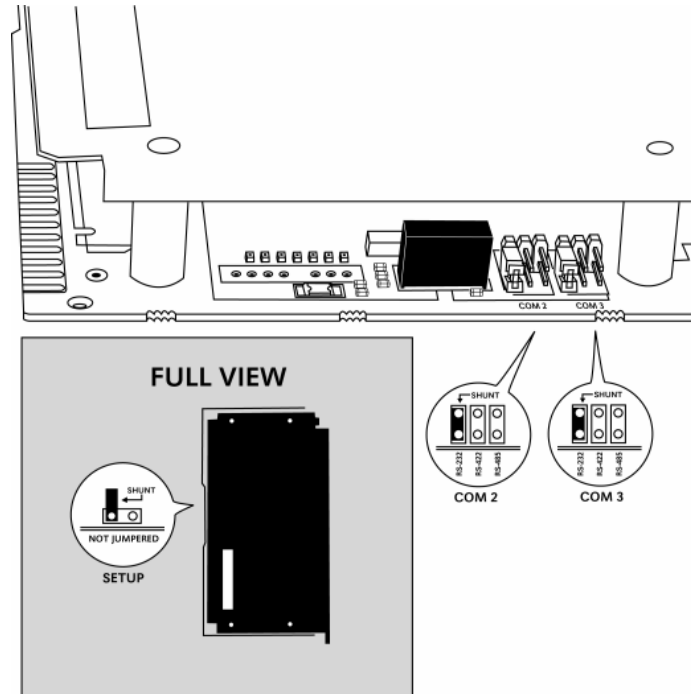

The Setup Jumper acts as "write protection" for the module's flash memory. In "write protected" mode, the Setup pins are not connected, and the module's firmware cannot be overwritten. Do not jumper the Setup pins together unless you are directed to do so by ProSoft Technical Support.

1.4 Install the Module in the Rack

If you have not already installed and configured your PLC processor and power supply, please do so before installing the MVI71-DNP module. Refer to your Rockwell Automation product documentation for installation instructions.

Warning: You must follow all safety instructions when installing this or any other electronic devices. Failure to follow safety procedures could result in damage to hardware or data, or even serious injury or death to personnel. Refer to the documentation for each device you plan to connect to verify that suitable safety procedures are in place before installing or servicing the device.

After you have checked the placement of the jumpers, insert MVI71-DNP into the PLC™ chassis. Use the same technique recommended by Rockwell Automation to remove and install PLC modules.

Warning: This module is not hot-swappable! Always remove power from the rack before inserting or removing this module, or damage may result to the module, the processor, or other connected devices.

- 1 Turn power OFF.
- 2 Align the module with the top and bottom guides, and slide it into the rack until the module is firmly against the backplane connector.

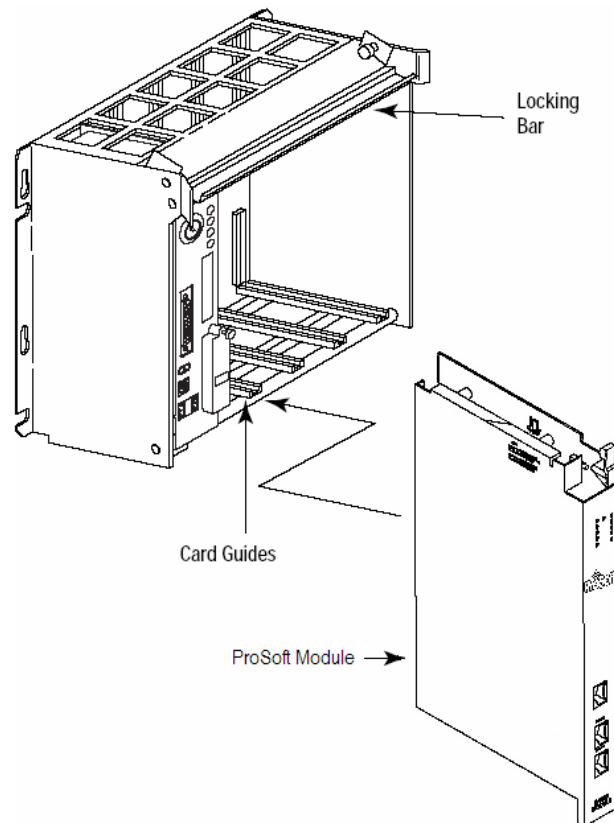

- 3 With a firm but steady push, snap the module into place.
- 4 Check that the holding clips on the top and bottom of the module are securely in the locking holes of the rack.
- 5 Make a note of the slot location. You will need to identify the slot in which the module is installed in order for the sample program to work correctly. Slot numbers are identified on the green circuit board (backplane) of the PLC rack.
- 6 Turn power ON.

Note: If you insert the module improperly, the system may stop working, or may behave unpredictably.

1.5 Connect your PC to the Processor

- 7 Connect the right-angle connector end of the cable to your controller at the communications port.

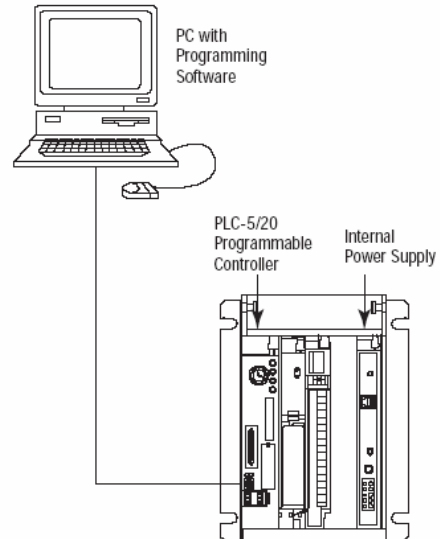

- 8 Connect the straight connector end of the cable to the serial port on your computer.

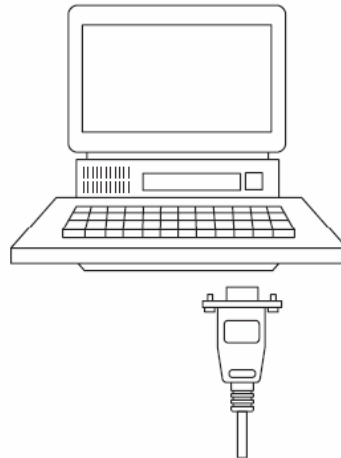

1.6 Download the Sample Program to the Processor

- **To download the sample program from RSLogix 5 to the PLC processor:**

Note: The key switch on the front of the PLC processor must be in the REM position.

- 1 If you are not already online to the processor, open the Communications menu, and then choose Download. RSLogix will establish communication with the processor.

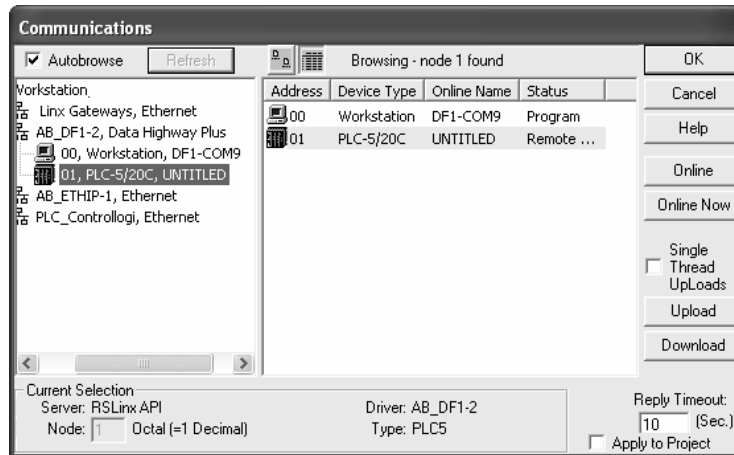

- 2 Click the Download button to transfer the sample program to the processor.
- 3 When prompted, choose Computer to PLC

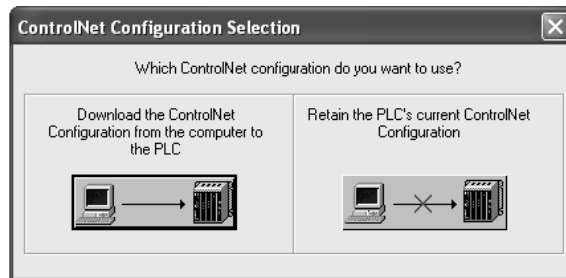

- 4 RSLogix will compile the program and transfer it to the processor. This process may take a few minutes.

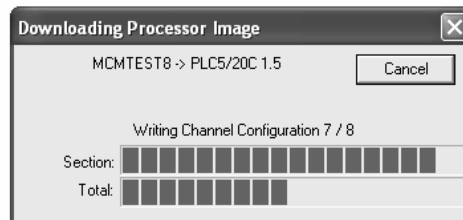

- 5 When the download is complete, RSLogix will open another confirmation dialog box. Click OK to switch the processor from Program mode to Run mode.

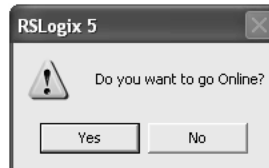

Note: If you receive an error message during these steps, refer to your RSLogix documentation to interpret and correct the error.

1.6.1 Configuring RSLinx

- **If RSLogix is unable to establish communication with the processor, follow these steps:**
- 1 Open RSLinx.
 - 2 Open the Communications menu, and choose Configure Drivers.

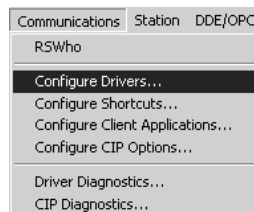

This action opens the Configure Drivers dialog box.

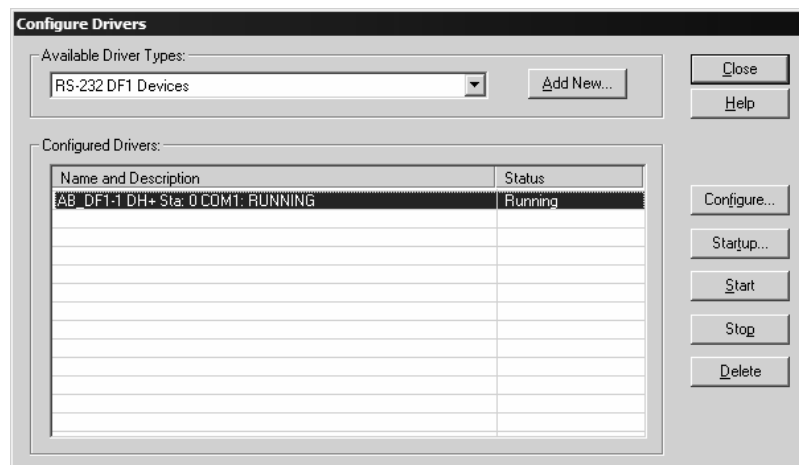

Note: If the list of configured drivers is blank, you must first choose and configure a driver from the Available Driver Types list. The recommended driver type to choose for serial communication with the processor is "RS-232 DF1 Devices".

- 3 Click to select the driver, and then click Configure. This action opens the Configure Allen-Bradley DF1 Communications Device dialog box.



- 4 Click the Auto-Configure button. RSLinx will attempt to configure your serial port to work with the selected driver.
- 5 When you see the message "Auto Configuration Successful", click the OK button to dismiss the dialog box.

Note: If the auto-configuration procedure fails, verify that the cables are connected correctly between the processor and the serial port on your computer, and then try again. If you are still unable to auto-configure the port, refer to your RSLinx documentation for further troubleshooting steps.

1.7 Connect your PC to the Module

With the module securely mounted, connect your PC to the Configuration/Debug port using an RJ45-DB-9 Serial Adapter Cable and a Null Modem Cable.

- 1 Attach both cables as shown.
- 2 Insert the RJ45 cable connector into the Configuration/Debug port of the module.
- 3 Attach the other end to the serial port on your PC or laptop.

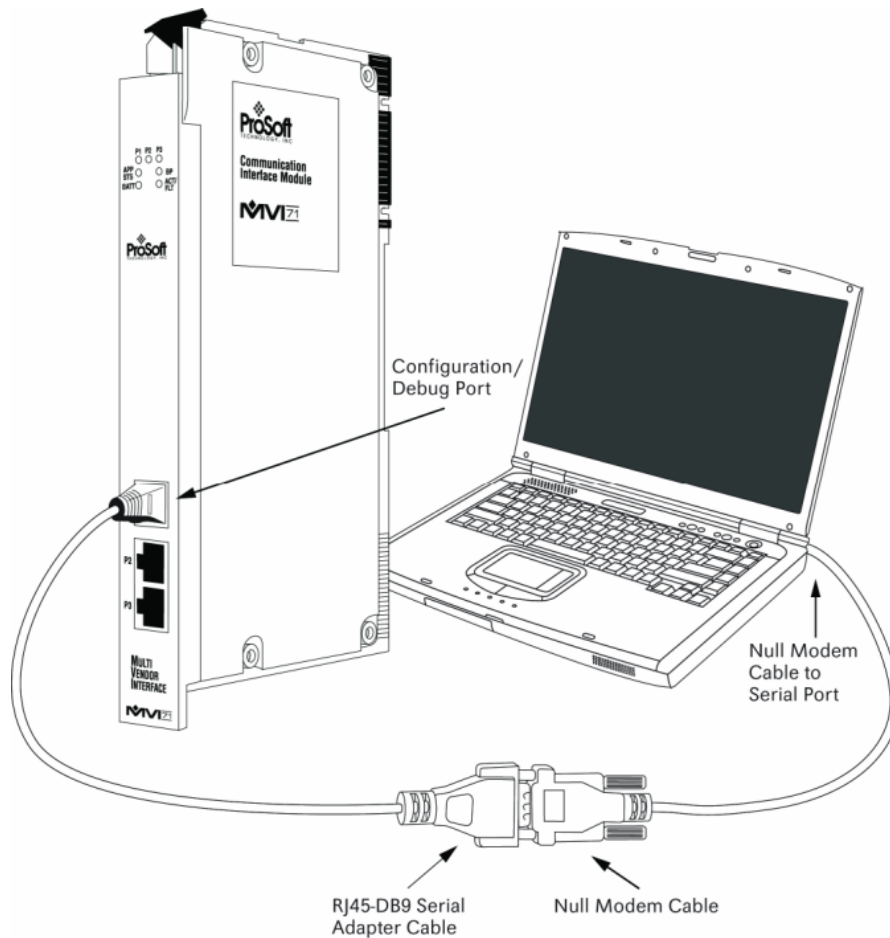

2 Installing and Configuring the Module

In This Chapter

- Module Data..... 23
- Configuration File..... 26
- Uploading and Downloading the Configuration File 50

This chapter describes how to install and configure the module to work with your application. The configuration process consists of the following steps.

- 1 Modify the module's configuration files to meet the needs of your application, and copy the updated configuration to the module. Example configuration files are provided on the CD-ROM. Refer to the **Modifying the Example Configuration File** section, later in this chapter, for more information on the configuration files.
- 2 Modify the example ladder logic to meet the needs of your application, and copy the ladder logic to the processor. Example ladder logic files are provided on the CD-ROM.

Note: If you are installing this module in an existing application, you can copy the necessary elements from the example ladder logic into your application.

The rest of this chapter describes these steps in more detail.

Before installing and configuring the module, design the application. Determine the number points for each data type. Review the **Application Design** section to aid in application design.

It is now time to edit the DNP.CFG file to set up the module for the specific application. Refer to the **Configuration File** section of this document. Download this configuration to the module along with the associated ladder logic.

The next step in installing and configuring the module is to define whether the block transfer or side-connect interface will be utilized. If the block transfer interface is to be used you should be ready to connect the module to the DNP network if the ladder logic is defined correctly. If the side-connect interface is to be used, you must obtain the side-connect kit, which is sold separately.

If the side-connect interface is utilized, make sure the file SC_DATA.TXT on the Compact Flash Disk contains the correct first file number. You can run the setdnpsc.exe program to set the file number to be used with your application. Install the module in the rack and turn on the power. Connect the terminal server to the module's debug/configuration port and exit the program by pressing the Esc key followed by the 'X' key. This will cause the program to exit and remain at the operating system prompt. Run the setdnpsc.exe program with a command line argument of the file number to use for the first file. For example, to select N10: as the first file, enter the following:

SETDNPSC 10

The program will build the SC_DATA.TXT on the Compact Flash Disk (C: drive in the root directory).

The next step in module setup is to define the data files to be used with the application. If the block transfer interface is used, define the data files to hold the user data (read and write data). Enter the ladder logic to handle the blocks transferred between the module and the PLC. Download the program to the PLC and test the program with the module.

If the side-connect interface is used, no ladder logic is required for data transfer. The user data files to interface with the module must reside in contiguous order in the processor. The first file to be used by the interface is the status/control file. This is file number set in the SC_DATA.TXT file using the SETDNPSC.EXE program. The following table lists the files used by the side-connect interface:

Cfg+#	File #	File Size	Description
0	N	150	Command control data starting at offset 80 (80 to 143 data area)
1	N		Reserved
2	N	124	Error/Status and Error List data destination
3	N	(960 max)	Digital input data source
4	N	(960 max)	Digital output data source
5	N	(960 max)	Counter data source and destination
6	N	(960 max)	Analog input data source
7	N	(960 max)	Analog output data destination
8	N	(960 max)	IED digital input data destination
9	N	(960 max)	IED digital output data source
10	N	(960 max)	IED counter data destination
11	N	(960 max)	IED analog input data destination
12	N	(960 max)	IED analog output data source
13	F	(240 max)	DNP slave floating-point input data
14	N		Reserved
15	F	(240 max)	DNP slave floating-point output data
16	N		Reserved

n is the number of read data files minus one. Each file contains up to a maximum of 960 words.

Special care must be taken when defining the files for the side-connect interface. Because the module directly interacts with the PLC processor and its memory, any errors in the configuration may cause the processor to fault and it may even lose its configuration and program. After defining the files and populating them with the correct data, download the program to the processor, and place the processor in run mode. If everything is configured correctly, the module should start its normal operation.

The module is now and ready to be used with your application. Insert the module in the rack (with the power turned off) and attach the serial communication cable. Download the new application to the controller and place the processor in run mode. Download the new DNP.CFGfile to the module using a terminal emulation program. If all the configuration parameters are set correctly and the module is attached to a network, the module's Application LED (APP LED) should remain off and the backplane activity LED (BP ACT) should blink very rapidly. Refer to the **Diagnostics and Trouble Shooting** section if you encounter errors. Attach a computer or terminal to Port 0 on the module and look at the status of the module using the Configuration/Debug Menu in the module.

2.1 Module Data

All data related to the MVI71-DNP module is stored in a user defined data file. It is the responsibility of the ladder logic programmer to construct all the data files required by the program and to write the ladder logic required to interface to these files.

2.1.1 Status Data

When the side-connect interface is employed in the application, the status data is automatically transferred from the module to the first file used by the interface. The data is placed at an offset of 0 in the file and has the following format:

Word	Variable Name	Description
0	Scan Counter	Program scan counter incremented each time the program loop is executed.
1 to 2	Product Name (ASCII)	These two words contain the product name of the module in ASCII format.
3 to 4	Revision (ASCII)	These two words contain the product revision level of the firmware in ASCII format.
5 to 6	Operating System Revision (ASCII)	These two words contain the module's internal operating system revision level in ASCII format.
7 to 8	Production Run Number (ASCII)	These two words contain the production 'batch' number for the particular chip in the module in ASCII format.
9	Read Block Count	Total number of blocks transferred from the module to the processor.
10	Write Block Count	Total number of blocks transferred from the processor to the module.
11	Parse Block Count	Total number of blocks parsed by the module that were received from the processor.

Word	Variable Name	Description
12	Block number error	Number of BTW requests that resulted in an incorrect BTW identification code.
13	DNP Slave Port total number of message frames received by slave	This value represents the total number of message frames that have matched this slaves address on this port. This count includes message frames which the slave may or may not be able to parse and respond.
14	DNP Slave Port total number of response message frames sent from slave	This value represents the number of good (non-error) responses that the slave has sent to the master on this port. The presumption is that if the slave is responding, the message was good. Note: This is a frame count.
15	DNP Slave Port total number of message frames seen by slave	This value represents the total number of message frames received by the slave, regardless of the slave address.
16	DNP Slave synchronization error count (Physical Layer Error)	This value counts the number of times a sync error occurs. The error occurs when extra bytes are received before the start bytes (0x05 and 0x64) are received.
17	DNP Slave overrun error count (Physical Layer Error)	This value counts the number of times the overrun error occurs. This error occurs when the mainline Data Link Layer routine cannot read the data received on the communication port before it is overwritten.
18	DNP Slave length error count (Physical Layer Error)	This value counts the number of times an invalid length byte is received. If the length of the message does not match the length value in the message, this error occurs.
19	DNP Slave bad CRC error (Data Link Layer Error)	This value counts the number of times a bad CRC value is received in a message.
20	DNP Slave user data overflow error (Transport Layer Error)	This value counts the number of times the application layer receives a message fragment buffer which is too small.
21	DNP Slave sequence error (Transport Layer Error)	This value counts the number of times the sequence numbers of multi-frame request fragments do not increment correctly.
22	DNP Slave address error (Transport Layer Error)	This value counts the number of times the source addresses contained in a multi-frame request fragments do not match.
23	DNP Slave Binary Input Event count	This value contains the total number of binary input events which have occurred.
24	DNP Slave Binary Input Event count in buffer	This value represents the number of binary input events which are waiting to be sent to the master.
25	DNP Slave Analog Input Event count	This value contains the total number of analog input events which have occurred.
26	DNP Slave Analog Input Event count in buffer	This value represents the number of analog input events which are waiting to be sent to the master.
27	DNP Slave bad function code error (Application Layer Error)	This value counts the number of times a bad function code for a selected object/variation is received by the slave device.

Word	Variable Name	Description
28	DNP Slave object unknown error (Application Layer Error)	This value counts the number of times a request for an unsupported object is received by the slave device.
29	DNP Slave out of range error (Application Layer Error)	This value counts the number of times a parameter in the qualifier, range or data field is not valid or out of range.
30	DNP Slave message overflow error (Application Layer Error)	This value counts the number of times an application response message from the slave is too long to transmit.
31	DNP Slave multi-frame message from DNP Master error (Application Layer Error)	This value counts the number of times the slave receives a multi-frame message from the master. The application does not support multi-frame master messages.
32	Free MemoryLSB	Free memory in module
33	Free MemoryMSB	

When the block transfer interface is used, the status data is placed in the module's internal database. If this data area is transferred to the processor in the read data area, it will be passed from the module to the processor in a normal BTR block. The format of the data is exactly the same as shown above, but the user determines its position. Refer to the Reference Chapter for a complete listing of the data stored in this object.

2.1.2 User Data

When the side-connect interface is utilized, the read and write data is moved between the module and the processor without any ladder logic. The size of the data area and position of the data areas in the module's database is determined by the parameters set in the configuration file.

When the block transfer interface is used, ladder logic is required to page the data between the module and the processor. The size of the data area and position of the data areas in the module's database is determined by the parameters set in the configuration file.

Module data is paged up to 60 words at a time from the module to the processor. The Ladder Logic task is responsible for placing the data received into the proper position in the data files.

2.2 Configuration File

In order for the module to operate, a configuration file (DNP.CFG) is required. This configuration file contains information to set the data transfer characteristics between the module and the processor, to configure the communication information, to establish the DNP protocol parameters and to define the databases required to hold the protocol data sets. Each parameter in the file must be set carefully in order for the application to be implemented successfully. Before editing the file, design your system using the forms located in the Reference chapter of this document.

The configuration file is separated into sections with topic header names enclosed in the [] characters. The configuration file consists of the following topics:

[Section]	Description
[Module]	General Module configuration section
[DNP Slave]	DNP slave protocol definitions
[DNP Slave Database]	Database definition for the DNP slave driver
[DNP Slave Binary Inputs]	Class assignments for each binary input point in the DNP database. These assignments will override the default setting.
[DNP Slave Analog Inputs]	Class and deadband assignments for each analog input point in the DNP database. These assignments will override the default settings.
[DNP Slave Float Inputs]	Class and deadband assignments for each analog floating-point input point in the DNP database. These assignments will override the default settings.
[Secondary Port]	Communication settings for the secondary port on the module (secondary slave or master port)
[DNP Master]	Definitions of the DNP Master port on the module if utilized
[IED Database]	Database definition for the DNP Master port to hold data to interface with the IEDs.
[DNP Master Slave List]	Slave set up information for the DNP Master port. This list contains the settings required for each IED unit the master will interface with.
[DNP Master Commands]	This list contains the command list to be utilized by the DNP Master port. These commands will be issued to configured IED units.

After each section header, the file contains a set of parameters. Unique labels are used under each section to specify a parameter. Each label in the file must be entered exactly as shown in the file for the parameter to be identified by the program. If the module is not considering a parameter, look at the label for the data item. Each parameter's value is separated from the label with the ':' character. This character is used by the program to delimit the position in the data record where to start reading data. All data for a parameter must be placed after the ':' character. For numeric parameter values any text located after the value will not be used. There must be at least one space character between the end of the parameter value and the following text. The following example shows a parameter entry:

```
RTS On : 6      #Set RTS On delay value from 0 to 65535 milliseconds
```

The parameter label is "RTS On" and the parameter value is 6. The characters after the parameter value are ignored and are used for internal documentation of the configuration file.

Any record that begins with the '#' character is considered to be a comment record. These records can be placed anywhere in the file as long as the '#' character is found in the first column of the line. These lines are ignored in the file and can be used to provide documentation within the configuration file. Liberal use of comments within the file can ease the use and interpretation of the data in the file.

Sections of the configuration file that contain lists of data are formatted differently. Each list begins with the label **START** and ends when the **END** label is reached. When entering the list data, make certain that the first character in each line is left blank.

2.2.1 [Module]

Module Name

0 to 80 characters

This parameter assigns a name to the module that can be viewed using the configuration/debug port. Use this parameter to identify the module and the configuration file.

2.2.2 [DNP Slave]

This section provides information required to configure a slave application with the module. Most entries contained within this section are self explanatory with the possible exception of the Use IP List directive. This directive instructs the module to verify the address of the received message and ignore the message if it is not on our list of acceptable clients. Another item of concern is the maximum size of the total database, although it is possible to configure a database of considerable size, this would not work, as the maximum Class 0 request may not exceed 2048 bytes in size.

The following example shows a sample [DNP Slave] section:

```
# This section is used to define the configuration for the Module.
# port. This port will receive requests from a remote DNP master unit.
#
[DNP Slave]
Internal Slave ID      : 6      #0-65534 slave identification code for this unit
# DNP slave communication port configuration
Baud Rate              : 19200  #Baud rate for port 110-115200
RTS On                 : 0      #0-32000 mSec before message
RTS Off                 : 0      #0-32000 mSec after message
Min Response Delay     : 0      #0-32000 mSec before response sent from slave

# DNP slave modem configuration
Modem                  : No     #Use a dial-up modem on this port (Yes or No)
```

```
Connect Timeout      : 20000 #0-65535 milliseconds before connect timeout
First Character Delay : 1000  #0-65535 milliseconds before 1st char after connect
Redial Delay Time    : 100   #0-65535 1/10 seconds min before redial attempt
Redial Random Delay  : 150   #0-65535 1/10 seconds random before redial attempt
Idle Timeout         : 200    #0-65535 1/10 seconds inactive timeout
Phone Number         : ATDT18001234567

# Collision Avoidance parameters
Collision Avoidance  : No      #Use Collision Avoidance (Yes or No)
CD Idle Time         : 10      #0-32000 mSec min idle time before transmit
CD Random Time       : 15      #0-32000 mSec random idle time before transmit
CD Time Before Receive : 5      #0-65535 milliseconds before receive

#Default Class Settings
BI Class             : 1       #Default class for binary input events
AI Class             : 2       #Default class for analog input events
Float Class          : 3       #Default class for float input events
Double Class         : 0       #(Not Used)

# DNP specific parameters
AI Deadband          : 10      #0-32767 analog deadband value for events
Float Deadband       : 10.0    #Single float deadband
Double Deadband      : 0       #(Not Used)
Select/Operate Arm Time: 2000  #1-65535 milliseconds arm timeout for select/op
outputs
Write Time Interval  : 60      #0-1440 minutes for time sync from master

Data Link Confirm Mode : Never  #DL confirm mode (N=Never,S=Sometimes,A=Always)
Data Link Confirm Tout : 1000  #1-65535 milliseconds DL confirm timeout
Data Link Max Retry    : 2       #0-255 maximum DL confirm retry count
App Layer Confirm Tout : 2000  #1-65535 milliseconds App Layer confirm timeout

Unsolicited Response  : No      #Generate Unsolicited responses (Yes or No)
Class 1 Unsol Resp Min : 2       #1-255 min number of events before send
Class 2 Unsol Resp Min : 3       #1-255 min number of events before send
Class 3 Unsol Resp Min : 4       #1-255 min number of events before send
Unsol Resp Delay      : 10000  #0-65535 milliseconds before events sent
UResp Master Address   : 2       #DNP address of master to send UResp data
UResp Retry Count     : 0       #0-255 Number of retries before switching ports

AI Events with time    : No      #timestamp AI Event data default (Yes or No)
Time Sync Before Events: No      #timesync module before events gen (Yes or No)
Initialize DNP Database: No      #Initialize the DNP Slave output database areas (Y/N)
```

Modify each parameter based on the needs of your application:

Internal Slave ID

```
Internal Slave ID    : 6        #0-65534 slave identification code for this unit
```

This is the DNP address for the module. All messages with this address received from the master will be processed by the module. This example shows the slave identification code of 6.

Baud Rate

Baud Rate : 19200 #Baud rate for port 110-115200

Primary DNP Port Baud Rate: 300, 600, 1200, 2400, 4800, 9600, 19200, 384 (38400) , 576 (57600), 115 (115200). The module has been tested for baud rates up to 19200.

RTS On

RTS On : 0 #0-65535 milliseconds before message

This value represents the number of 1 ms increments to be inserted between asserting the RTS modem line and the actual transmission of the data.

RTS Off

RTS Off : 0 #0-65535 milliseconds after message

This value represents the number of 1 ms increments to be inserted after the last character of data is transmitted before the RTS modem line is dropped.

Minimum Response Delay

Min Response Delay : 0 #0-65535 milliseconds before response sent from slave

Minimum time between receiving a request and transmitting a response. Allows master time to disable transmitter on an RS-485 network.

Modem

Modem : No #Use a dial-up modem on this port (Yes or No)

This parameter defines if a dial-up modem is used on the secondary DNP slave port. A modem cannot be used if the port is configured as a master.

Connect Timeout

Connect Timeout : 20000 #0-65535 milliseconds before connect timeout

Defines the number of milliseconds to wait for the CD signal to be set high. The CD signal indicates a connection is made using a dial-up modem.

First Character Delay

First Character Delay : 1000 #0-65535 milliseconds before 1st char after connect

Defines the number of milliseconds to wait before sending the first message after the connection is first made. This delay only applies to the first packet sent to the modem.

Redial Delay Time

Redial Delay Time : 100 #0-65535 1/10 seconds min before redial attempt

Defines the minimum number of milliseconds to wait before a redial attempt is made by the slave.

Redial Random Delay

Redial Random Delay : 150 #0-65535 1/10 seconds random before redial attempt

Defines a random millisecond time range to be added to the redial delay time before the modem is accessed.

Idle Timeout

Idle Timeout : 200 #0-65535 1/10 seconds inactive timeout

Defines the number of milliseconds the modem is inactive before it will disconnect.

Phone Number

Phone Number : ATDT18001234567

This field contain a null-terminated, ASCII character string used by the dial-up modem. The string must contain all characters required by the modem. An example string is ATDT18001234567. Maximum length is 34 bytes including the terminating 0.

Collision Avoidance

Collision Avoidance : No #Use Collision Avoidance (Yes or No)

This parameter defines if collision avoidance will be utilized on the primary DNP slave port.

CD Idle Time

CD Idle Time : 10 #0-32000 mSec min idle time before transmit

Defines the minimum number of milliseconds to wait before transmitting a message after the CD signal is recognized as low.

CD Random Time

CD Random Time : 15 #0-32000 mSec random idle time before transmit

Defines the range of random time to be added to the CD Idle Time before a message will be transmitted from the slave.

CD Time Before Receive

CD Time Before Receive : 5 #0-65535 milliseconds before receive

Defines the number of milliseconds to wait before receiving characters after the CD signal is recognized as high.

BI Class

0=disable, else 1 to 3

This parameter specifies the default class to be utilized for all the binary input points in the DNP database that are not defined in the override list section.

AI Class

0=disable, else 1 to 3

This parameter specifies the default class to be utilized for all the analog input points in the DNP database that are not defined in the override list section.

Float Class

0=disable, else 1 to 3

This parameter specifies the default class to be utilized for all the floating-point input points in the DNP database that are not defined in the override list section.

AI Deadband

AI Deadband : 1 #0-32767 analog deadband value for events

This parameter specifies the default deadband value assigned to all points not defined in the override list for the analog input point type in the DNP database.

Float Deadband

Float Deadband : 1000.0 #Single float deadband

This parameter specifies the default deadband value assigned to all points not defined in the override list for the floating-point input point type in the DNP database.

Double Deadband

Double Deadband : 4000.0 #Double float deadband (Not Used)

This parameter specifies the default deadband value assigned to all points not defined in the override list for the double floating-point input point type in the DNP database.

Select/Operate Arm Time

Select/Operate Arm Time: 2000 #1-65535 milliseconds arm timeout for select/op outputs

Time period after select command received in which operate command will be performed. After the select command is received, the operate command will only be honored if it arrives within this period of time.

Write Time Interval

Write Time Interval : 60 #0-1440 minutes for time sync from master

Time interval to set the need time IIN bit (0=never), which will cause the master to write the time. For example, if this parameter is configured for 60 minutes, it would mean 60 minutes after the last write date and time request. The module would set the "Need Time" bit again.

Data Link Confirm Mode

Data Link Confirm Mode : Never #DL confirm mode (N=Never, S=Sometimes, A=Always)

IED can request acknowledgement from master station when sending data. The codes are as follows: 0=Never, 1=Sometimes, 2=Always.

Data Link Confirm Tout

Data Link Confirm Tout : 1000 #1-65535 milliseconds DL confirm timeout

Time period to wait for Master Data Link confirmation of last frame sent. This time is in milliseconds. This parameter is only used if the frame is sent with confirmation requested.

Data Link Max Retry

Data Link Max Retry : 2 #0-255 maximum DL confirm retry count

Maximum number of retries at the Data Link level to obtain a confirmation. If this value is set to 0, retries are disabled at the data link level of the protocol. This parameter is only used if the frame is sent with confirmation requested.

App Layer Confirm Tout

App Layer Confirm Tout : 2000 #1-65535 milliseconds App Layer confirm timeout

Event data contained in the last response may be sent again if not confirmed within the millisecond time period set. If application layer confirms are used with data link confirms, ensure that the application layer confirm timeout is set long enough.

Unsolicited Response

Unsolicited Response : No #Generate Unsolicited responses (Yes or No)

Set if the slave unit will send unsolicited response messages. If set to No, the slave will not send unsolicited responses. If set to Yes, the slave will send unsolicited responses. The module will send the event when one of the following conditions are satisfied:

- 1 Minimum number of events is reached
- 2 Delay time is reached

Class 1 Unsol Resp Min

Class 1 Unsol Resp Min : 10 #1-255 min number of events before send

Minimum number of events in Class 1 required before an unsolicited response will be generated.

Class 2 Unsol Resp Min

Class 2 Unsol Resp Min : 10 #1-255 min number of events before send

Minimum number of events in Class 2 required before an unsolicited response will be generated.

Class 3 Unsol Resp Min

Class 3 Unsol Resp Min : 10 #1-255 min number of events before send

Minimum number of events in Class 3 required before an unsolicited response will be generated.

Unsol Resp Delay

Unsol Resp Delay : 2000 #0-65535 milliseconds before events sent

Maximum number of 1 millisecond intervals to wait after an event occurs before sending an unsolicited response message. If set to 0, only use minimum number of events.

UResp Master Address

UResp Master Address : 1 #DNP address of master to send UResp data

DNP destination address where unsolicited response messages are sent.

UResp Retry Count

UResp Retry Count : 0 #0-255 Number of retries before switching ports

Determines the number of unsolicited message retries sent on primary DNP port before changing to secondary port. If the value is 0, port switching will be disabled.

AI Events with Time

AI Events with time : No #timestamp AI Event data default (Yes or No)

This parameter sets if the analog input events generated by the module will include the date and time of the event. If the parameter is set to No, the default is set to no time data. If the parameter is set to Yes, the default object will include the time of the event.

Time Sync Before Events

Time Sync Before Events: No #timesync module before events gen (Yes or No)

This parameter determines if events are to be generated by the module before the time synchronization from the master unit. If the parameter is set to Yes, no events will be generated until the module's time has been synchronized. If the parameter is set to No, events will always be generated.

Initialize DNP Database

Initialize DNP Database: No #Initialize the DNP Slave output database areas (Y/N)

This parameter determines if the module will request data from the processor to initialize the DNP database output data areas. During the first scan, the module will read all output points from the processor to initialize its internal database.

2.2.3 [DNP Slave Database]

The following shows an example [DNP Slave Database] section:

```
[DNP Slave Database]
Binary Inputs           : 160    #0-8000 point count to hold BI data
PLC Binary Inputs      : 160    #0-8000 BI point count from PLC
Analog Inputs          : 10     #0-500 points of analog input data
PLC Analog Inputs      : 10     #0-500 analog input points from PLC
Float Inputs           : 10     #0-250 points of floating-point format data
PLC Float Inputs       : 10     #0-250 points of floating-point format data
Double Inputs          : 0      #(Not Used)
PLC Double Inputs      : 0      #(Not Used)
Counters               : 10     #0-250 points of counter data
PLC Counters           : 10     #0-250 counter points from PLC
Binary Outputs         : 160    #0-2000 point count to hold BO data
PLC Binary Outputs     : 160    #0-2000 BO point count from PLC
Analog Outputs         : 10     #0-500 points of analog output data
PLC Analog Outputs     : 10     #0-500 analog output points from PLC
Float Outputs          : 10     #0-250 points of floating-point format data
PLC Float Outputs      : 10     #0-250 points of floating-point format data
Double Outputs         : 0      #(Not Used)
PLC Double Outputs     : 0      #(Not Used)
```

Edit each parameter as required for your application. The following topics describe each parameter.

Binary Inputs

```
Binary Inputs           : 160    #0-8000 point count to hold BI data
```

Number of digital input points to configure in the DNP slave device. Each point will be stored as a single bit in the module memory.

PLC Binary Inputs

```
PLC Binary Inputs      : 160    #0-8000 BI point count from PLC
```

Number of digital input points configured above that are to be obtained from the processor. All other binary input points must come from the attached IED units.

Analog Inputs

```
Analog Inputs          : 50     #0-500 points of analog input data
```

Number of analog input points to configure in the DNP slave device. Each point will occupy a one word area in the module memory.

PLC Analog Inputs

```
PLC Analog Inputs      : 50     #0-500 analog input points from PLC
```

Number of analog input points configured above that are to be obtained from the processor. All other analog input points must come from the attached IED units.

Float Inputs

Float Inputs : 5 #0 to 250 points of floating-point format data

Number of floating-point input points to configure in the DNP slave device. Each point will occupy a two-word area in the module memory.

PLC Float Inputs

PLC Float Inputs : 5 #0-250 points of floating-point format data

Number of floating-point input points configured above that are to be obtained from the PLC.

Counters

Counters : 20 #0-250 points of counter data

Number of counter points to configure in the DNP slave device. Each point will occupy a two word area in the module memory. This number corresponds to the number of frozen counters. The application maps the counters to the frozen counters directly.

PLC Counters

PLC Counters : 20 #0-250 counter points from PLC

Number of counter points configured above that are to be obtained from the processor. All other counter points must come from the attached IED units.

Binary Outputs

Binary Outputs : 160 #0-2000 point count to hold BO data

Number of digital output points to configure in the DNP slave device. Each point will be stored as a single bit in the module memory.

PLC Binary Outputs

PLC Binary Outputs : 160 #0-2000 BO point count from PLC

Number of digital output points configured above that are to be sent to the processor. All other binary output points will be sent to the attached IED units.

Analog Outputs

Analog Outputs : 28 #0-500 points of analog output data

Number of analog output points to configure in the DNP slave device. Each point will occupy a one word area in the module memory.

PLC Analog Outputs

PLC Analog Outputs : 28 #0-500 analog output points from PLC

Number of analog output points configured above that are to be sent to the processor. All other analog output points will be sent to the attached IED units.

Float Outputs

Float Outputs : 4 #0-250 points of floating-point format data

Number of floating-point output points to configure in the DNP slave device. Each point will occupy a two- word area in the module memory.

PLC Float Outputs

PLC Float Outputs : 4 #0-250 points of floating-point format data

Number of floating-point output points configured above that are to be sent to the processor.

2.2.4 [DNP Slave Binary Inputs]

This section of the configuration file overrides the Class 2 binary database points. Enter the list of points between the start and end labels:

```
[DNP Slave Binary Inputs]
# This area is to override the class (2) binary input database points.
#
# Point#   Class
Start
#   0       1
#   1       2
#   2       3
#   3       0   #Events will never be generated for this point
End
```

This section takes the following parameters:

Parameter Number	Parameter Name	Parameter Description
1	Point #	This is the information object address of the point.
2	Class	Class 1 – Highest priority Class 2 – Middle priority Class 3 – Lowest priority 0 – Disable.

2.2.5 [DNP Slave Analog Inputs]

This section of the configuration file overrides the Class 3 and deadband for the integer analog input database. The point number is the offset from the start of the analog input database.

```
[DNP Slave Analog Inputs]
# This area is to override the class (3) and deadband for the integer analog
# input database. The point # is the offset from the start of the analog
# input database.
#
# Point#   Class   Deadband
Start
#   6       1       2000 #points 0-5=class 1, deadband = 1000
#   7       1       2000
#   8       2       1000
End
```

This section takes the following parameters:

Parameter Number	Parameter Name	Parameter Description
1	Point #	This is the information object address of the point.
2	Class	Class 1 – Highest priority Class 2 – Middle priority Class 3 – Lowest priority 0 – Disable
3	Deadband	A range of values within which the module will avoid generating events.

2.2.6 [DNP Slave Float Inputs]

This area overrides the Class 3 and deadband for the single float database. The point number is not the address in the analog database, but rather the offset from the start of the single floating-point database.

[DNP Slave Float Inputs]

```
# This area is to override the class (3) and deadband for the single float
# database. The point # is not the address in the analog database, but is
# the offset from the start of the single floating-point database.
#
# Point#   Class   Deadband
Start
  0         1       100.
  1         2       12.34
  3         0       13.45 #Events will never be generated for this point
  4         2       3000.0 #points 5 to 11=class 1, deadband = 1000.00
End
```

This section takes the following parameters:

Parameter Number	Parameter Name	Parameter Description
1	Point #	This is the information object address of the point.
2	Class	Class 1 – Highest priority Class 2 – Middle priority Class 3 – Lowest priority 0 – Disable.
3	Deadband	A range of values within which the module will avoid generating events.

2.2.7 [Secondary Port]

The following is an example of the [Secondary Port] section:

[Secondary Port]

```
Type           : M      #' '=Disabled, M=Master, S=Slave
Baud Rate      : 19200  #Baud rate for port 110-115200
RTS On         : 10    #0-65535 milliseconds before message
RTS Off        : 0     #0-65535 milliseconds after message
Min Response Delay : 0   #0-65535 milliseconds before response sent from
slave
```

```
# Collision Avoidance parameters
Collision Avoidance : No      #Use Collision Avoidance (N=No, Y=Yes)
CD Idle Time       : 10      #0-32000 mSec min idle time before transmit
CD Random Time     : 20      #0-32000 mSec random idle time before transmit
CD Time Before Receive : 6    #0-65535 milliseconds before receive
```

Configure each parameter to work with your application.

Type

```
Type : M      #' '=Disabled, M=Master, S=Slave
```

This parameter defines the functionality of the secondary port on the module.

M = emulate a DNP master port

S = back-up DNP slave port to the primary port.

Any other value will disable the port.

Baud Rate

```
Baud Rate : 19200 #Baud rate for port 110-115200
```

Secondary DNP Port Baud Rate: 300, 600, 1200, 2400, 4800, 9600, 19200, 384 (38400) , 576 (57600), 115 (115200).

RTS On

```
RTS On : 10      #0-65535 milliseconds before message
```

This value represents the number of 1 ms increments to be inserted between asserting the RTS modem line and the actual transmission of the data.

RTS Off

```
RTS Off : 0      #0-65535 milliseconds after message
```

This value represents the number of 1 ms increments to be inserted after the last character of data is transmitted before the RTS modem line is dropped.

Min Response Delay

```
Min Response Delay : 0      #0-65535 milliseconds before response sent from slave
```

Minimum time between receiving a request and transmitting a response. Allows master time to disable transmitter on an RS-485 network.

Collision Avoidance

```
Collision Avoidance : No      #Use Collision Avoidance (N=No, Y=Yes)
```

This parameter defines if collision avoidance will be utilized on the primary DNP slave port.

CD Idle Time

CD Idle Time : 10 #0-32000 mSec min idle time before transmit

Defines the minimum number of milliseconds to wait before transmitting a message after the CD signal is recognized as low.

CD Random Time

CD Random Time : 20 #0-32000 mSec random idle time before transmit

Defines the range of random time to be added to the CD Idle Time before a message will be transmitted from the slave.

CD Time Before Receive

CD Time Before Receive : 6 #0-65535 milliseconds before receive

Defines the number of milliseconds to wait before receiving characters after the CD signal is recognized as high.

2.2.8 [DNP Master]

The following shows an example of the [DNP Master] section:

```
[DNP Master]
Internal ID : 1 #0-65534 identification code for this unit
Initialize IED Database: Yes #Initialize the IED input database areas (Y/N)
Event Messages to PLC : Yes #Pass received events to processor (Y/N)
```

Configure each parameter to suit the needs of your application:

Internal ID

Internal ID : 1 #0-65534 identification code for this unit

This is the DNP address for the module. All messages with this address from the master will be processed by the module.

Initialize IED Database

Initialize IED Database: Yes #Initialize the IED input database areas (Y/N)

This parameter determines if the module will request data from the processor to initialize the IED database input data areas. If this option is utilized, ladder logic is required to send the requested block from the processor to the module.

Event Messages to PLC

Event Messages to PLC : Yes #Pass received events to processor (Y/N)

Enables the pass-through functionality that allows the module to pass received timestamp events from the remote slave device to the processor. It requires the configuration of block 9903 in the backplane command section. Refer to the Block 9903 section of this User Manual for further information.

2.2.9 [IED Database]

The following shows an example of an [IED Database] section:

```
[IED Database]
Binary Inputs      : 160  #0-2048 point count to hold BI data
Analog Inputs     : 50   #0-256 points of analog input data
Counters          : 10   #0-64  points of counter data
Binary Outputs    : 48   #0-2048 point count to hold BO data
Analog Outputs    : 8    #0-128 points of analog output data
```

Binary Inputs

```
Binary Inputs      : 160  #0-2048 point count to hold BI data
```

Number of binary input points contained in the IED database to transfer to the processor and obtained from the attached IED units.

Analog Inputs

```
Analog Inputs     : 50   #0-256 points of analog input data
```

Number of analog input points contained in the IED database to transfer to the processor and obtained from the attached IED units.

Counters

```
Counters          : 10   #0-64  points of counter data
```

Number of counter points contained in the IED database to transfer to the processor and obtained from the attached IED units.

Binary Outputs

```
Binary Outputs    : 48   #0-2048 point count to hold BO data
```

Number of binary output points contained in the IED database which are transferred from the processor and used by the attached IED units.

Analog Outputs

```
Analog Outputs    : 8    #0-128 points of analog output data
```

Number of analog output points contained in the IED database, which are transferred from the processor and used by the attached IED units.

2.2.10 [DNP Master Slave List]

The [DNP Master Slave List] section stores information about each slave being used by the master port. There must be an entry in this table for each node to be used in the command list. Two of the parameters in this list are coded values and are described in the following two sections.

```
[DNP Master Slave List]
# This section is used to store information about each slave to be
# used by the master port.  There must be an entry in this table for each
# node to be used in the command list.  Two of the parameters in this list
# are coded values:
#   Conf Mode ==> 0=Never, 1=Sometimes and 2=Always (select 0).
#   Flags is bit coded as follows:
#     Bit 0 (decimal 1) ==> Enable the slave
#     Bit 1 (decimal 2) ==> Use Unsolicited messaging with this slave
#     Bit 2 (decimal 4) ==> Use delay measurement with this slave
#     Bit 3 (decimal 8) ==> Auto time synchronization enabled
#
START
#   Node DL Conf      Conf   Conf  App Rsp
# Address   Mode  Timeout  Retry  Timeout  Flags
#         32    0    1000    0    7000    9
END
```

2.2.11 [DNP Master Commands]

The [DNP Master Commands] section contains the list of commands to process on the master port. Node addresses present in the command list must have an entry in the [DNP Slave List]. Commands with nodes not present in the list will not be executed. The module supports up to 100 commands.

The following shows an example of a [DNP Master Commands] section:

```
[DNP Master Commands]
# This section contains the list of commands to process on the master port.
# Node addresses present in the command list must have an entry in the
# [DNP Slave List]. Commands with nodes not present in the list will not be
# executed.
#
START
#   1      2      3      4      5      6      7      8      9      10
#Flags/  Node  Data      Data  Cmd  Device Point  DNP DB  IED DB  Poll
#Enable Address Object Variation Func Address Count Address Address Interval
#   6      32    60      5      1      0      60    -1     -1      2
#   6      32     1      1      1      0      60    -1      0      5
#   6      32    30      1      1      0      50    -1      0      6
END
```

This section takes the following parameters:

Parameter Number	Parameter Name	Parameter Description
1	Flags/Enable	See following topics for descriptions
2	Node Address	

Parameter Number	Parameter Name	Parameter Description
3	Data Object	
4	Data Variation	
5	Cmd Func	
6	Device Address	
7	Point Count	
8	DNP DB Address	
9	IED DB Address	
10	Poll Interval	

The definition of each parameter required for each command is provided in the following table.

Bits in the Port/Flags parameter are dependent on the data type. The following table defines the Port/Flags bits for binary input, analog input and counter data points.

Port/Flags Bits	Description	Decimal Equivalent
0 to 1	Communication port (0=Internal, 1=Port 1, 2=Port 2, 3=Port 3)	0 to 3
2	Enable/Disable Command (1=Enable, 0=Disable)	4
3	RBE Flag (0=Events from IED, 1=Events by module)	8
4 to 7	Not Used	

For these data types the qualifier used in the data request is dependent on the Point Count and Address in Slave fields in the command as follows:

- If Point Count < 0, then use Qualifier 06h (All points, packed & -Point Count = # of points to consider)
- If Address in Slave = 0 & Point Count > 0, then use Qualifier 00h or 01h (points 0 to Point Count -1)
- If Address in Slave > 0 & Point Count > 0, then use Qualifier 00h or 01h (Address in Slave to Address in Slave + Point Count -1)

The following table defines the Port/Flags bits for binary output and analog output points.

Port/Flags Bits	Description	Decimal Equivalent
0 to 1	Communication port (0=Internal, 1=Port 1, 2=Port 2, 3=Port 3)	0 to 3
2	Enable/Disable Command (1=Enable, 0=Disable)	4
3	Poll Type (0=Poll, 1=Exception)	8
4	Data Source (0=DNP Database, 1=IED Database)	16
5 to 7	Not Used	

For these data types the qualifier used in the data request is dependent on the Point Count and Address in Slave fields in the command as follows:

- If Address in Slave = 0 & Point Count > 0, then use Qualifier 17h or 28h (Point Count specified starting at point 0)

- If Address in Slave > 0 & Point Count > 0, then use Qualifier 17h or 28h (points from Address in Slave to Address in Slave + Point Count – 1)
- If Point Count <= 0, then ignore because this is illegal for outputs.

Node Address

This parameter specifies the IED unit address on the DNP network to consider with the command. The parameter has a range of 0 to 65535. The value of 65535 is reserved for broadcast messages. Be certain the slave configuration information is set up in the module for each slave defined in the command list.

Data Object

This parameter specifies the DNP object type in the command. Valid objects for the module are 1, 2, 12, 20, 21, 30, 32, 41, 50, 60 and 80. A value of 0 is permitted in this field for a set of special commands.

Data Variation

This parameter is specific to the object type selected.

Cmd Function

This parameter specifies the DNP function for the command list object. The object type determines the value of the functions permitted. For example, the only function permitted for binary input data points is the read function (Function Code 1). For counter and output objects, more functions are available.

Device Address

This value must be greater-than or equal to zero. If it is set to a value less-than zero, the command will be ignored. This parameter specifies the starting point address to consider in the IED unit.

Point Count

This parameter defines the number of points in the IED unit. Refer to the discussion above for the interpretation of this parameter's values for the different object types.

DNP DB Address

This parameter defines the starting location in the DNP database to be used with the command. If the parameter has a value of –1, the DNP database is not used with the point.

IED DB Address

This parameter defines the starting location in the IED database to be used with the command. If the parameter has a value of –1, the IED database is not used with the point.

Poll Interval

This parameter specifies the minimum frequency at which the module should execute the command. The value is entered in units of seconds. For example, to execute a command every 10 seconds, enter a value of 10 in the field. A value of 0 for the parameter implies that the command should be executed every scan of the list.

Binary Input Command Examples

	Port/Flg	Slave	Object	Var	Func	Addr	Pnt Cnt	DNP DB	IED DB	Poll Int
Word	0	1	2	3	4	5	6	7	8	9
Value	6	15	1	0	1	0	-32	200	-1	2

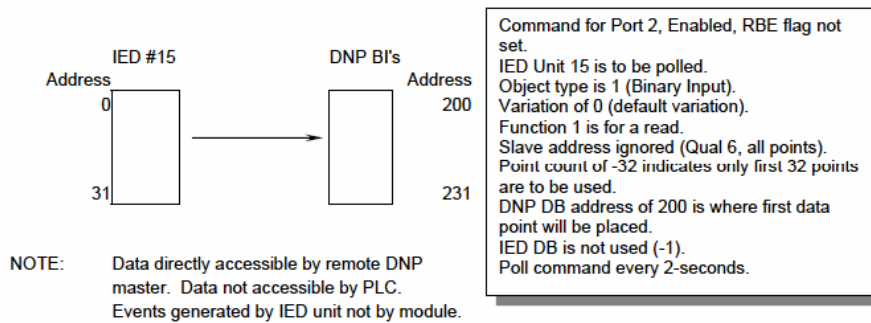

	Port/Flg	Slave	Object	Var	Func	Addr	Pnt Cnt	DNP DB	IED DB	Poll Int
Word	0	1	2	3	4	5	6	7	8	9
Value	6	15	1	0	1	0	-32	-1	0	2

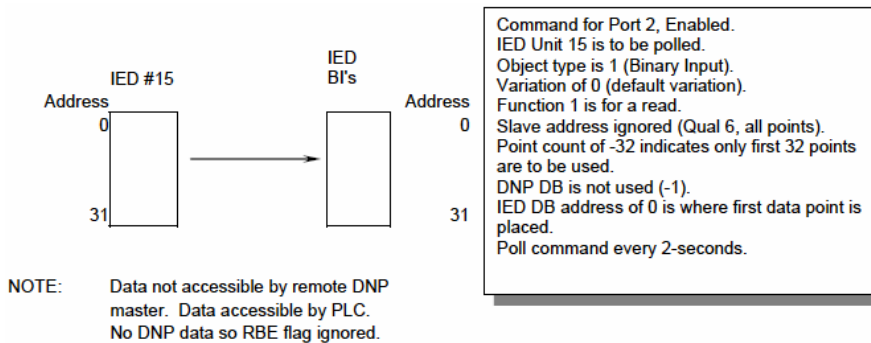

	Port/ Flg	Slave	Object	Var	Func	Addr	Pnt Cnt	DNP DB	IED DB	Poll Int
Word	0	1	2	3	4	5	6	7	8	9
Value	14	15	1	0	1	0	-32	200	0	2

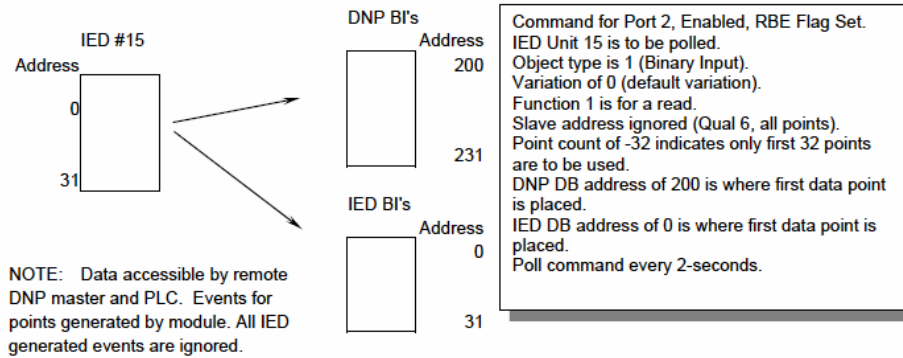

Binary Output Command Examples

	Port/ Flg	Slave	Object	Var	Func	Addr	Pnt Cnt	DNP DB	IED DB	Poll Int
Word	0	1	2	3	4	5	6	7	8	9
Value	14	15	12	1	5	10	2	200	0	0

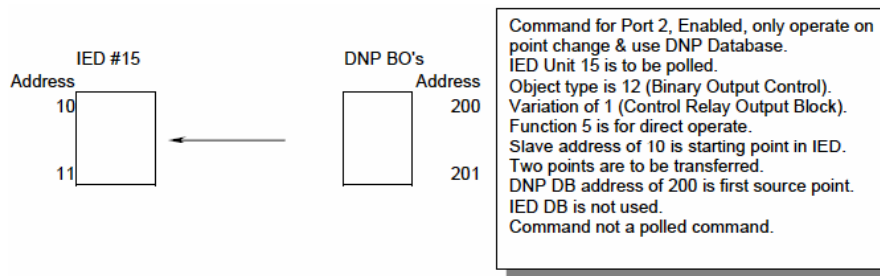

	Port/ Flg	Slave	Object	Var	Func	Addr	Pnt Cnt	DNP DB	IED DB	Poll Int
Word	0	1	2	3	4	5	6	7	8	9
Value	30	15	12	1	5	10	1	0	25	0

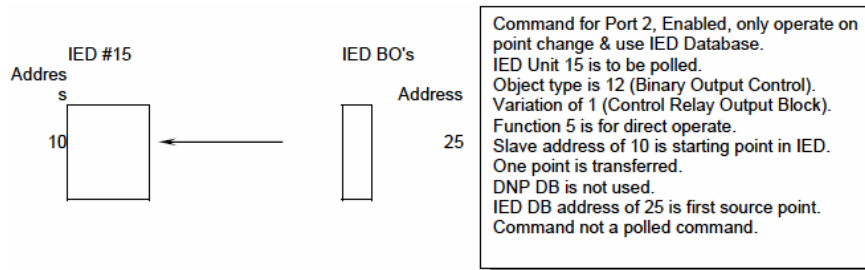

	Port/ Flg	Slave	Object	Var	Func	Addr	Pnt Cnt	DNP DB	IED DB	Poll Int
Word	0	1	2	3	4	5	6	7	8	9
Value	6	15	12	1	5	100	10	200	0	120

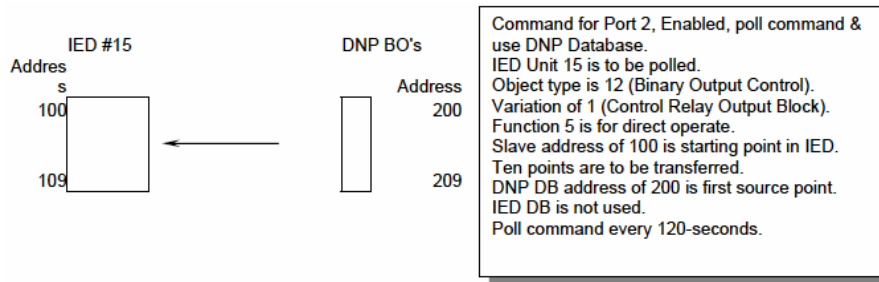

2.2.12 Slave List

The slave list defines the IED units and their specific communication parameters for a DNP master port. Up to 40 IED units can be defined in the module to be associated with the master port. The structure of each row in the list is defined in the following table:

Column	Variable Name	Data Range	Description	IF Error
1	DNP Slave Address	0 to 65534	This is the slave address for the unit to override the default values.	Ignore
2	Data Link Confirm Mode	Coded Value (0=Never, 1=Sometimes, 2=Always)	This value specifies if data link frames sent to the remote device require a data link confirm. This value should always be set to zero for almost all applications.	0
3	Data Link Confirm Time-out	1 to 65535 milliseconds	This parameter specifies the time to wait for a data link confirm from the remote device before a retry is attempted.	300
4	Maximum Retries for Data Link Confirm	0 to 255 retries	Maximum number of retries at the Data Link level to obtain a confirmation. If this value is set to 0, retries are disabled at the data link level of the protocol. This parameter is only used if the frame is sent with confirmation requested.	3
5	Application Layer Response Time-out	1 to 65535 milliseconds	Time-out period the master will wait for each response message fragment. If data link confirms are enabled, make sure the time-out period is set long enough to permit all data confirm retries.	5000

Column	Variable Name	Data Range	Description	IF Error
6	Slave Mode	Coded Value (Bit 0=Enable, Bit 1=Unsol Msg, Bit 2=Use DM, Bit 3=Auto Time Sync)	This word contains bits that define the slave mode. The slave mode defines the functionality of the slave device and can be combined in any combination. The fields have the following definition: Enable: determines if this slave will be used. Unsol Msg: causes an enabled unsolicited response message to be sent to the slave when its RESTART IIN bit is set. This parameter is also required for unsolicited message reporting by the IED unit. Use DM: uses delay measurement. Auto Time Sync: time synchronization used when NEED TIME IIN bit set.	5

2.2.13 Command List

The command list stores the command list used by the DNP master port. This list only must be defined if the DNP master port is used. Up to 300 commands can be defined for the master port. The structure of each row in the list is shown in the following table:

Word Offset	Definitions
0	Port/Flags
1	Slave Address
2	Object
3	Variation
4	Function
5	Address in Slave
6	Point Count
7	DNP DB Address
8	IED DB Address
9	Poll Interval

The definition of each parameter required for each command is provided in the following table.

Bits in the Port/Flags parameter are dependent on the data type. The following table defines the Port/Flags bits for binary input, analog input and counter data points.

Port/Flags Bits	Description	Decimal Equivalent
0 to 1	Communication port (0=Internal, 2=Port 2, 3=Port 3). Any value from 1 to 3 sends out P2 (Master Port)	0 to 3
2	Enable/Disable Command (1=Enable, 0=Disable)	4
3	RBE Flag(0=Events from IED, 1=Events by module)	8

Port/Flags Bits	Description	Decimal Equivalent
4 to 7	Not Used	

For these data types the qualifier used in the data request is dependent on the Point Count and Address in Slave fields in the command as follows:

If Point Count < 0, then use Qualifier 06h (All points, packed & -Point Count = # of points to consider)

If Address in Slave = 0 & Point Count > 0, then use Qualifier 00h or 01h (points 0 to Point Count –1)

If Address in Slave > 0 & Point Count > 0, then use Qualifier 00h or 01h (Address in Slave to Address in Slave + Point Count –1)

The following table defines the Port/Flags bits for binary output and analog output points.

Port/Flags Bits	Description	Decimal Equivalent
0 to 1	Communication port(0=Internal, 1=Port 1, 2=Port 2, 3=Port 3). Any value from 1 to 3 sends out P2 (Master Port)	0 to 3
2	Enable/Disable Command (1=Enable, 0=Disable)	4
3	Poll Type (0=Poll, 1=Exception)	8
4	Data Source(0=DNP Database, 1=IED Database)	16
5 to 7	Not Used	

For these data types the qualifier used in the data request is dependent on the Point Count and Address in Slave fields in the command as follows:

If Address in Slave = 0 & Point Count > 0, then use Qualifier 17h or 28h (Point Count specified starting at point 0)

If Address in Slave > 0 & Point Count > 0, then use Qualifier 17h or 28h (points from Address in Slave to Address in Slave + Point Count –1)

If Point Count <= 0, then ignore because this is illegal for outputs.

Slave Address

This parameter specifies the IED unit address on the DNP network to consider with the command. The parameter has a range of 0 to 65535. The value of 65535 is reserved for broadcast messages. Be certain the slave configuration information is set up in the module for each slave defined in the command list.

Object

This parameter specifies the DNP object type in the command. Valid objects for the module are 1, 2, 12, 20, 21, 30, 32, 41, 50, 60 and 80. A value of 0 is permitted in this field for a set of special commands.

Variation

This parameter is specific to the object type selected.

Function

This parameter specifies the DNP function for the command list object. The object type determines the value of the functions permitted. For example, the only function permitted for binary input data points is the read function (Function Code 1). For counter and output objects, more functions are available.

Address In Slave

This value must be greater-than or equal to zero. If it is set to a value less-than zero, the command will be ignored. This parameter specifies the starting point address to consider in the IED unit.

Point Count

This parameter defines the number of points in the IED unit. Refer to the discussion above for the interpretation of this parameter's values for the different object types.

DNP DB Address

This parameter defines the starting location in the DNP database to be used with the command. If the parameter has a value of -1, the DNP database is not used with the point.

IED DB Address

This parameter defines the starting location in the IED database to be used with the command. If the parameter has a value of -1, the IED database is not used with the point.

The IED database is the only database that will send and receive data to and from the PLC processor.

Poll Interval

This parameter specifies the minimum frequency at which the module should execute the command. The value is entered in units of seconds. For example, to execute a command every 10 seconds, enter a value of 10 in the field. A value of 0 for the parameter implies that the command should be executed every scan of the list.

2.3 Uploading and Downloading the Configuration File

ProSoft modules are shipped with a pre-loaded configuration file. In order to edit this file, you must transfer the file from the module to your PC. After editing, you must transfer the file back to the module.

This section describes these procedures.

Important: The illustrations of configuration/debug menus in this section are intended as a general guide, and may not exactly match the configuration/debug menus in your own module. For specific information about the configuration/debug menus in your module, refer to The Configuration/Debug Menu.

2.3.1 Transferring the Configuration File to Your PC

- 1 Connect your PC to the Configuration/Debug port of the module using a terminal program such as HyperTerminal. Press [?] to display the main menu.

```

***** DNP DEBUG PORT HELP *****
KEY      FUNCTION                      | KEY FUNCTION
-----|-----
0-9,A-F  Sets debug level                | Y   Class/Deadband Assignments
L        Display error list            | U   Show DNP Databases
P        Display setup & pointers      | <  Receive Configuration
O        Operating parameters          | >  Send Configuration
R        Reboot module
S        Display Comm Stats
W        Clear error list              | N   Display Blk X-fer Stats
V        List COM States               | X   Master Port Commands
T        Master Port Slave Setup       | Z   Master Port Slave Errs
G        Version Information           | ?   Display this screen

PRODUCT = DNP5   REVISION = 2.35   OP SYS REV = 1206   PROD RUN # = 1501
  
```

- 2 Press [>] key (Send Module Configuration). The message "Press Y to confirm configuration send!" is displayed at the bottom of the screen.

```

***** DNP DEBUG PORT HELP *****
KEY      FUNCTION                      | KEY FUNCTION
-----|-----
0-9,A-F  Sets debug level                | Y   Class/Deadband Assignments
L        Display error list            | U   Show DNP Databases
P        Display setup & pointers      | <  Receive Configuration
O        Operating parameters          | >  Send Configuration
R        Reboot module
S        Display Comm Stats
W        Clear error list              | N   Display Blk X-fer Stats
V        List COM States               | X   Master Port Commands
T        Master Port Slave Setup       | Z   Master Port Slave Errs
G        Version Information           | ?   Display this screen

PRODUCT = DNP5   REVISION = 2.35   OP SYS REV = 1206   PROD RUN # = 1501
Confirm Receive Configuration File from Remote PC by pressing 'Y' key...
  
```

- Press [Y]. The module will automatically start a Zmodem file transfer. The configuration file will be stored in the default file transfer folder on your PC.

- Note:** ProSoft Technology suggests that you download the configuration file pre-loaded on your module. However, configuration files are also available on the ProSoft CD as well as the ProSoft Technology web site at <http://www.prosoft-technology.com>.

When the configuration file has been transferred to your PC, the dialog box will indicate that the transfer is complete.

```

0-9,A-F Sets debug level           | Y  Class/Deadband Assignments
L      Display error list          | U  Show DNP Databases
P      Display setup & pointers    | <  Receive Configuration
O      Operating parameters        | >  Send Configuration
R      Reboot module
S      Display Comm Stats
W      Clear error list            | N  Display Blk X-fer Stats
V      List COM States             | X  Master Port Commands
T      Master Port Slave Setup     | Z  Master Port Slave Errs
G      Version Information         | ?  Display this screen

PRODUCT = DNP5   REVISION = 2.35   OP SYS REV = 1206   PROD RUN # = 1501
Confirm Send Configuration File to Remote PC by pressing 'Y' key....
Sending configuration file:

TRANSFERRING CONFIGURATION FILES FROM MVI MODULE TO PC:

Select RECEIVE menu option and receive files *.*
èCONFIGURATION FILE TRANSFERRED TO PC.

```

The configuration file is now in a folder on your PC. To view the location of this folder, open the Transfer menu in Hyperterminal and choose Receive File.

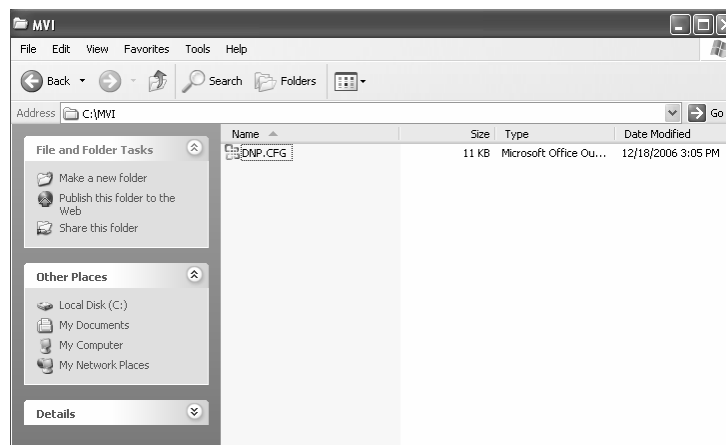

- You can now open and edit the file in a text editor such as Notepad. When you have finished editing the file, save it and close Notepad.

Important: You must name this file DNP.CFG before you transfer it to the module. The module will not recognize configuration files with any other name or extension.

2.3.2 Transferring the Configuration File to the Module

Perform the following steps to transfer a configuration file from your PC to the module.

- 1 Connect your PC to the Configuration/Debug port of the module using a terminal program such as HyperTerminal. Press [?] to display the main menu.

```
***** DNP DEBUG PORT HELP *****
KEY      FUNCTION                | KEY FUNCTION
-----|-----
0-9,A-F Sets debug level         | Y   Class/Deadband Assignments
L        Display error list       | U   Show DNP Databases
P        Display setup & pointers | <   Receive Configuration
O        Operating parameters    | >   Send Configuration
R        Reboot module
S        Display Comm Stats
W        Clear error list         | N   Display Blk X-fer Stats
V        List COM States          | X   Master Port Commands
T        Master Port Slave Setup  | Z   Master Port Slave Errs
G        Version Information      | ?   Display this screen

PRODUCT = DNP5  REVISION = 2.35  OP SYS REV = 1206  PROD RUN # = 1501
```

- 2 Press [<] (Receive Module Configuration). The message "Press Y key to confirm configuration receive!" is displayed at the bottom of the screen.

```
***** DNP DEBUG PORT HELP *****
KEY      FUNCTION                | KEY FUNCTION
-----|-----
0-9,A-F Sets debug level         | Y   Class/Deadband Assignments
L        Display error list       | U   Show DNP Databases
P        Display setup & pointers | <   Receive Configuration
O        Operating parameters    | >   Send Configuration
R        Reboot module
S        Display Comm Stats
W        Clear error list         | N   Display Blk X-fer Stats
V        List COM States          | X   Master Port Commands
T        Master Port Slave Setup  | Z   Master Port Slave Errs
G        Version Information      | ?   Display this screen

PRODUCT = DNP5  REVISION = 2.35  OP SYS REV = 1206  PROD RUN # = 1501
Confirm Receive Configuration File from Remote PC by pressing 'Y' key...
```

- 3 Press [Y]. The screen now indicates that the PC is ready to send.

```

***** DNP DEBUG PORT HELP *****
KEY      FUNCTION                               | KEY FUNCTION
-----|-----
0-9,A-F Sets debug level                       | Y   Class/Deadband Assignments
L        Display error list                     | U   Show DNP Databases
P        Display setup & pointers               | <   Receive Configuration
O        Operating parameters                   | >   Send Configuration
R        Reboot module                          |
S        Display Comm Stats                     |
W        Clear error list                       | N   Display Blk X-fer Stats
V        List COM States                        | X   Master Port Commands
T        Master Port Slave Setup                | Z   Master Port Slave Errs
G        Version Information                    | ?   Display this screen

PRODUCT = DNP5   REVISION = 2.35   OP SYS REV = 1206   PROD RUN # = 1501

Confirm Receive Configuration File from Remote PC by pressing 'Y' key...
Receiving configuration file:

TRANSFERRING CONFIGURATION FROM PC TO MVI MODULE:
Select SEND menu option and send file DNP.CFG

è*†B000000027fed4

```

- 4 From the **Transfer** menu in HyperTerminal, select **Send File**.

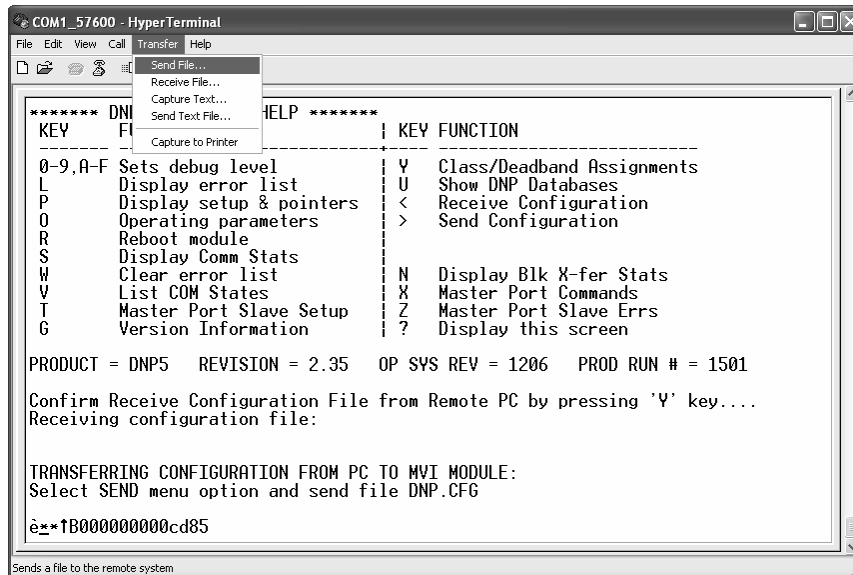

```

COM1_57600 - HyperTerminal
File Edit View Call Transfer Help
Send File...
Receive File...
Capture Text...
Send Text File...
Capture to Printer

***** DNP DEBUG PORT HELP *****
KEY      FUNCTION                               | KEY FUNCTION
-----|-----
0-9,A-F Sets debug level                       | Y   Class/Deadband Assignments
L        Display error list                     | U   Show DNP Databases
P        Display setup & pointers               | <   Receive Configuration
O        Operating parameters                   | >   Send Configuration
R        Reboot module                          |
S        Display Comm Stats                     |
W        Clear error list                       | N   Display Blk X-fer Stats
V        List COM States                        | X   Master Port Commands
T        Master Port Slave Setup                | Z   Master Port Slave Errs
G        Version Information                    | ?   Display this screen

PRODUCT = DNP5   REVISION = 2.35   OP SYS REV = 1206   PROD RUN # = 1501

Confirm Receive Configuration File from Remote PC by pressing 'Y' key...
Receiving configuration file:

TRANSFERRING CONFIGURATION FROM PC TO MVI MODULE:
Select SEND menu option and send file DNP.CFG

è*†B00000000cd85

Sends a file to the remote system.

```

The Send File dialog appears.

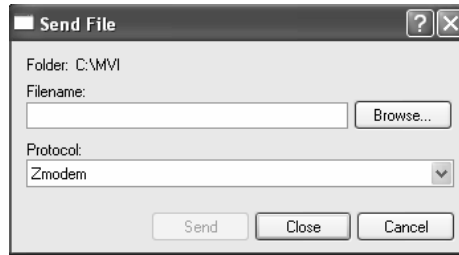

- 5 Use the Browse button to locate the configuration file your computer.

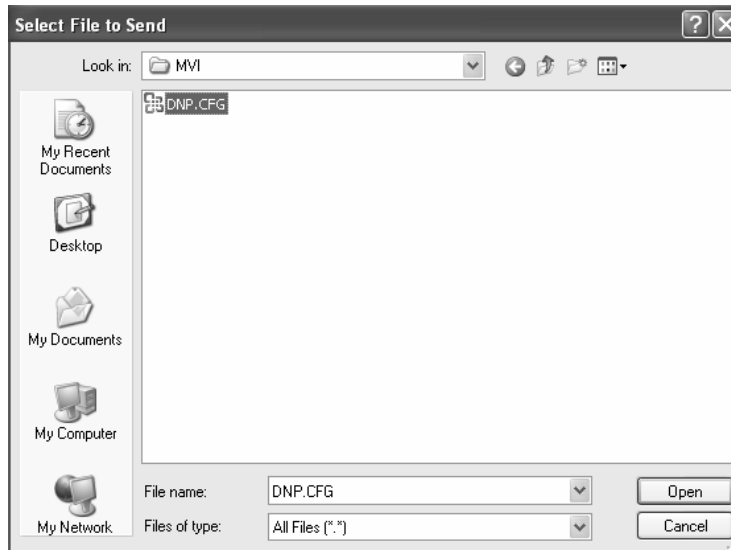

Note: This procedure assumes that you are uploading a newly edited configuration file from your PC to the module. However, configuration files are also available on the ProSoft CD as well as the ProSoft Technology web site.

- 6 Select Zmodem as the protocol.
- 7 Click the Send button. This action opens the Zmodem File Send dialog box.

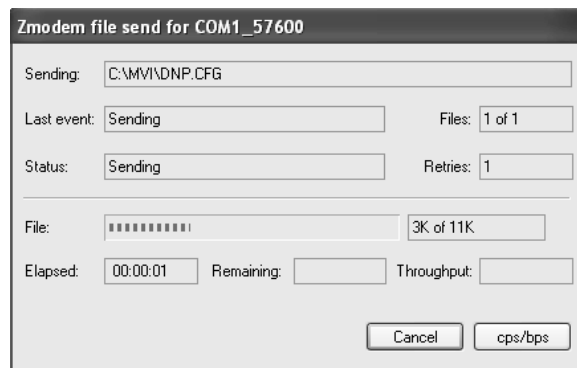

When the upload is complete, the screen indicates that the module has reloaded program values and displays information about the module.

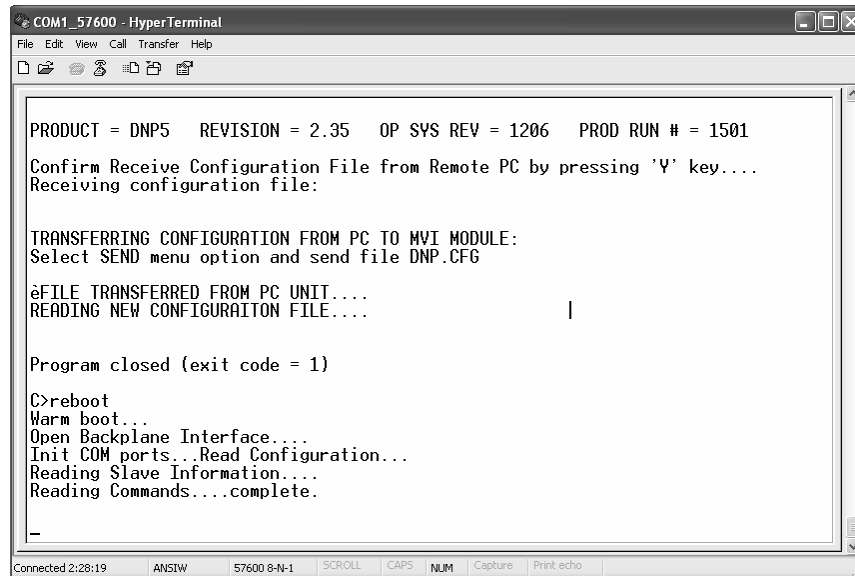

```
COM1_57600 - HyperTerminal
File Edit View Call Transfer Help
[Icons]
-----
PRODUCT = DNP5  REVISION = 2.35  OP SYS REV = 1206  PROD RUN # = 1501
Confirm Receive Configuration File from Remote PC by pressing 'V' key...
Receiving configuration file:

TRANSFERRING CONFIGURATION FROM PC TO MVI MODULE:
Select SEND menu option and send file DNP.CFG

FILE TRANSFERRED FROM PC UNIT...
READING NEW CONFIGURAITON FILE...

Program closed (exit code = 1)

C>reboot
Warm boot...
Open Backplane Interface...
Init COM ports..Read Configuration...
Reading Slave Information...
Reading Commands....complete.

-----
Connected 2:28:19  ANSIW  57600 8-N-1  SCROLL  CAPS  NUM  Capture  Print echo
```

- 8 Your module now contains the new configuration. Press [?] to see the module's main menu.

3 Ladder Logic

Ladder logic is required for application of the MVI71-DNP module. Tasks that must be handled by the ladder logic are module data transfer, special block handling and status data receipt. Additionally, a power-up handler may be needed to handle the initialization of the module's data and to clear any processor fault conditions.

The sample ladder logic, on the ProSoft Solutions CD-ROM, is extensively commented, to provide information on the purpose and function of each rung. For most applications, the sample ladder will work without modification.

4 Diagnostics and Troubleshooting

In This Chapter

- Reading Status Data From the Module 59
- LED Status Indicators 72
- Clearing a Fault Condition 72
- Troubleshooting 73

The module provides information on diagnostics and troubleshooting in the following forms:

- Status data values are transferred from the module to the processor.
- Data contained in the module can be viewed through the Configuration/Debug port attached to a terminal emulator.
- LED status indicators on the front of the module provide information on the module's status.

4.1 Reading Status Data From the Module

The MVI71-DNP module returns a Status Data block that can be used to determine the module's operating status. This data is located in the module's database status database and error status list. This data is transferred to the PLC processor read blocks with an identification code of 100. For a complete listing of the status data object, refer to the Installing and Configuring the Module section.

4.1.1 The Configuration/Debug Menu

The Configuration and Debug menu for this module is arranged as a tree structure, with the Main Menu at the top of the tree, and one or more sub-menus for each menu command. The first menu you see when you connect to the module is the Main menu.

Because this is a text-based menu system, you enter commands by typing the command letter from your computer keyboard in the terminal application (for example, HyperTerminal). The module does not respond to mouse movements or clicks. The command executes as soon as you press the command letter — you do not need to press **[Enter]**. When you type a command letter, a new screen will be displayed in your terminal application.

Navigation

All of the sub-menus for this module contain commands to redisplay the menu or return to the previous menu. You can always return from a sub-menu to the next higher menu by pressing **[M]** on your keyboard.

The organization of the menu structure is represented in simplified form in the following illustration:

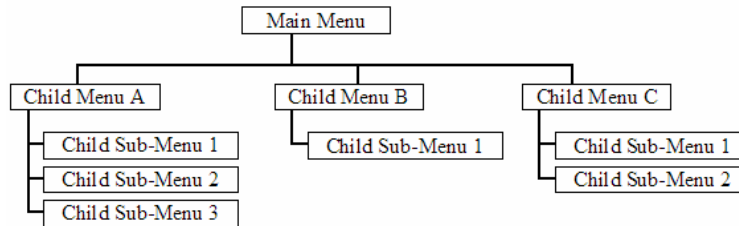

The remainder of this section shows you the menus available for this module, and briefly discusses the commands available to you.

Keystrokes

The keyboard commands on these menus are almost always non-case sensitive. You can enter most commands in lower case or capital letters.

The menus use a few special characters (**[?]**, **[-]**, **[+]**, **[@]**) that must be entered exactly as shown. Some of these characters will require you to use the **[Shift]**, **[Ctrl]** or **[Alt]** keys to enter them correctly. For example, on US English keyboards, enter the **[?]** command as **[Shift][/]**.

Also, take care to distinguish capital letter **[I]** from lower case letter **[i]** (L) and number **[1]**; likewise for capital letter **[O]** and number **[0]**. Although these characters look nearly the same on the screen, they perform different actions on the module.

4.1.2 Required Hardware

You can connect directly from your computer's serial port to the serial port on the module to view configuration information, perform maintenance, and send (upload) or receive (download) configuration files.

ProSoft Technology recommends the following minimum hardware to connect your computer to the module:

- 80486 based processor (Pentium preferred)
- 1 megabyte of memory
- At least one UART hardware-based serial communications port available. USB-based virtual UART systems (USB to serial port adapters) often do not function reliably, especially during binary file transfers, such as when uploading/downloading configuration files or module firmware upgrades.
- A null modem serial cable.

4.1.3 Required Software

In order to send and receive data over the serial port (COM port) on your computer to the module, you must use a communication program (terminal emulator).

A simple communication program called HyperTerminal is pre-installed with recent versions of Microsoft Windows operating systems. If you are connecting from a machine running DOS, you must obtain and install a compatible communication program. The following table lists communication programs that have been tested by ProSoft Technology.

DOS	ProComm, as well as several other terminal emulation programs
Windows 3.1	Terminal
Windows 95/98	HyperTerminal
Windows NT/2000/XP	HyperTerminal

The module uses the Ymodem file transfer protocol to send (upload) and receive (download) configuration files from your module. If you use a communication program that is not on the list above, please be sure that it supports Ymodem file transfers.

4.1.4 Using the Configuration/Debug Port

To connect to the module's Configuration/Debug port:

- 1 Connect your computer to the module's port using a null modem cable.
- 2 Start the communication program on your computer and configure the communication parameters with the following settings:

Baud Rate	57,600
Parity	None
Data Bits	8
Stop Bits	1
Software Handshaking	XON/XOFF

- 3 Open the connection. When you are connected, press the [?] key on your keyboard. If the system is set up properly, you will see a menu with the module name followed by a list of letters and the commands associated with them.

If there is no response from the module, follow these steps:

- 1 Verify that the null modem cable is connected properly between your computer's serial port and the module. A regular serial cable will not work.
- 2 Verify that RSLinx is not controlling the COM port. Refer to [Disabling the RSLinx Driver for the Com Port on the PC](#) (page 111).
- 3 Verify that your communication software is using the correct settings for baud rate, parity and handshaking.
- 4 On computers with more than one serial port, verify that your communication program is connected to the same port that is connected to the module.

If you are still not able to establish a connection, you can contact ProSoft Technology Technical Support for further assistance.

4.1.5 Main Menu

When you first connect to the module from your computer, your terminal screen will be blank. To activate the main menu, press the [?] key on your computer's keyboard. If the module is connected properly, the following menu will appear on your terminal screen:

```

***** DNP DEBUG PORT HELP *****
KEY      FUNCTION                               | KEY FUNCTION
-----|-----
0-9,A-F  Sets debug level                       | Y   Class/Deadband Assignments
L         Display error list                   | U   Show DNP Databases
P         Display setup & pointers             | <   Receive Configuration
O         Operating parameters                 | >   Send Configuration
R         Reboot module                       |
S         Display Comm Stats                  |
W         Clear error list                    | N   Display Blk X-fer Stats
V         List COM States                     | X   Master Port Commands
T         Master Port Slave Setup             | Z   Master Port Slave Errs
G         Version Information                 | ?   Display this screen

PRODUCT = DNP5   REVISION = 2.35   OP SYS REV = 1206   PROD RUN # = 1501
    
```

Caution: Some of the commands available to you from this menu are designed for advanced debugging and system testing only, and can cause the module to stop communicating with the processor or with other devices, resulting in potential data loss or other failures. Only use these commands if you are specifically directed to do so by ProSoft Technology Technical Support staff. Some of these command keys are not listed on the menu, but are active nevertheless. Please be careful when pressing keys so that you do not accidentally execute an unwanted command.

Setting the Debug Level

You can increase or decrease the level of debug messages sent from the module to the Debug Menu. The following table shows the type of debugging information for each key [0] to [9], [A] to [F]

Key	None	DNP Statistics	Data Link Layer Messages	DPA Level Messages
0	X			
1		X		
2			X	
3		X	X	
4				
5		X		
6			X	
7		X	X	
8				X
9		X		X
A			X	X
B		X	X	X

Key	None	DNP Statistics	Data Link Layer Messages	DPA Level Messages
C				X
D		X		X
E			X	X
F		X	X	X

Viewing the Error List

Press **[L]** to display the last 60 errors for the DNP slave port. Refer to the error list section of the user manual to interpret each error recorded by the module.

If there are no errors present for the module, the message "NO ERRORS FOR SYSTEM!" is displayed.

Viewing DNP Set Up & Pointers

Press **[P]** to display the memory allocation and the database setup parameters.

Viewing Operating Parameters

Press **[O]** to view the DNP Protocol setup information (Operating Parameters) for the module.

Warm Booting the Module

Caution: Some of the commands available to you from this menu are designed for advanced debugging and system testing only, and can cause the module to stop communicating with the processor or with other devices, resulting in potential data loss or other failures. Only use these commands if you are specifically directed to do so by ProSoft Technology Technical Support staff. Some of these command keys are not listed on the menu, but are active nevertheless. Please be careful when pressing keys so that you do not accidentally execute an unwanted command.

Press **[R]** from the Main Menu to warm boot (restart) the module. This command will cause the program to exit and reload, refreshing configuration parameters that must be set on program initialization. Only use this command if you must force the module to re-boot.

Viewing Comm Stats

Press **[S]** to view the communication status for the DNP port.

Clearing the Error List

Press **[W]** to clear the error list. Use this command after viewing the error list (page 63) to delete the current list of errors and start a new list.

Viewing COM States

Press **[V]** to view the current state of the DNP application port and the port configuration information.

Viewing Master Port Slave Setup

Press **[T]** to view configuration information for the Master Port Slave.

Viewing Version Information

Press **[G]** to view Version information for the module.

Use this command to view the current version of the software for the module, as well as other important values. You may be asked to provide this information when calling for technical support on the product.

Values at the bottom of the display are important in determining module operation. The Program Scan Counter value is incremented each time a module's program cycle is complete.

Tip: Repeat this command at one-second intervals to determine the frequency of program execution.

Opening the Class Assignment Menu

Press **[Y]** to view the class and deadband override values for the binary, analog, float and double input DNP database.

Opening the DNP Database View Menu

Press **[U]** to open the DNP Database View Menu. This menu allows you to view all data associated with the DNP Server driver. For more information about the commands on this menu, refer to [DNP Database View Menu](#) (page 67).

Receiving the Configuration File

Press **[<] (Shift Comma)** to download (receive) the current configuration file from the module. For more information on receiving and sending configuration files, please see [Uploading and Downloading the Configuration File](#) (page 50).

Sending the Configuration File

Press **[>] (Shift Period)** to upload (send) an updated configuration file to the module. For more information on receiving and sending configuration files, please see [Uploading and Downloading the Configuration File](#) (page 50).

Viewing Block Transfer Statistics

Press **[N]** from the Main Menu to view the Block Transfer Statistics screen.

Use this command to display the configuration and statistics of the backplane data transfer operations between the module and the processor. The information on this screen can help determine if there are communication problems between the processor and the module.

Tip: Repeat this command at one-second intervals to determine the number of blocks transferred each second.

Opening the Command List Menu

Press **[X]** to open the Command List menu. Use this command to view the configured command list for the module.

```

***** DNP MASTER PORT COMMAND SELECTION MENU *****
PRODUCT = DNP      REVISION = 1.00  OP SYS REV = 0900  PROD RUN # = 1501
SELECT RANGE OF COMMANDS TO VIEW USING ONE OF THE KEYS INDICATED.
KEY-COMMANDS      KEY-COMMANDS      KEY-COMMANDS      KEY-COMMANDS      KEY-COMMANDS
0 - 0-19          1 - 20-39          2 - 40-59          3 - 60-79          4 - 80-99
5 - 100-119      6 - 120-139       7 - 140-159       8 - 160-179       9 - 180-199
A - 200-219      B - 220-239       C - 240-259       D - 260-279       E - 280-299
  
```

Opening the Command Error List Menu

Press **[Z]** to open the Command Error List. This list consists of multiple pages of command list error/status data. Press **[?]** to view a list of commands available on this menu.

```

***** DNP MASTER PORT SLAVE SELECTION MENU *****
PRODUCT = DNP      REVISION = 1.00  OP SYS REV = 0900  PROD RUN # = 1501
SELECT RANGE OF SLAVES TO VIEW USING ONE OF THE KEYS INDICATED.
KEY-SLAVES        KEY-SLAVES        KEY-SLAVES        KEY-SLAVES
0 - 0-9           1 - 10-19         2 - 20-29         3 - 30-39
  
```

4.1.6 The Class Assignment Menu

This menu allows you to view the class and deadband override values for the binary, analog, float and double input DNP database. Press **[?]** to display the commands available on this menu.

```

CLASS ASSIGNMENT MENU
?=Display Menu
0=Binary Inputs
1=Analog Inputs
2=Float Inputs
3=Double Inputs
S=Show Again
P=Previous Page
N=Next Page
M=Main Menu
  
```

The following illustration shows the output for the Analog data set (menu key **[1]**)

POINT#	CLASS	DEADBAND
0	1	1000
1	1	1000
2	1	1000
3	1	1000
4	1	1000
5	1	1000
6	1	2000
7	1	2000
8	2	1000
9	3	2000
10	2	1000
11	2	1000
12	1	1000
13	1	1000
14	1	1000
15	1	1000
16	1	1000
17	1	1000
18	1	1000
19	1	1000

Viewing Binary Inputs

Press **[0]** to view the override values for Binary Input Data.

Viewing Analog Inputs

Press **[1]** to view the override values for Analog Input Data.

Viewing Float Inputs

Press **[2]** to view the override values for Float Input Data.

Viewing Double Inputs

Press **[3]** to view the override values for Double Input Data.

Redisplaying the Current Page

Press **[S]** to display the current page of data.

Viewing the Previous Page of Data

Press **[P]** to display the previous page of data.

Viewing the Next Page of Data

Press **[N]** to display the next page of data.

Returning to the Main Menu

Press **[M]** to return to the Main Menu.

4.1.7 DNP Database View Menu

Use this menu command to view the current contents of the selected database.
Press [?] to view a list of commands available on this menu.

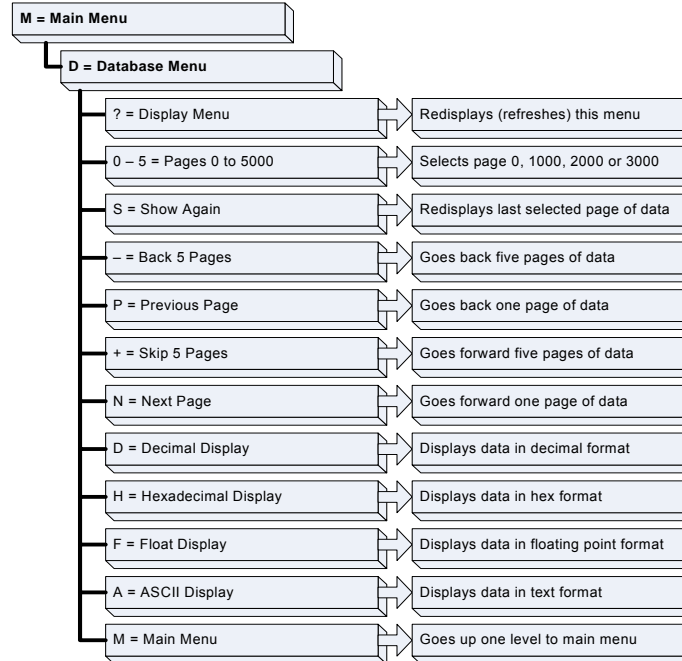

```

? = Display Menu
S = Show Again
- = Back 5 Pages
P = Previous Page
+ = Skip 5 Pages
N = Next Page
D = Word Decimal Display
H = Word Hexadecimal Display
L = Double Word Decimal Display
X = Double Word Hexadecimal Display
F = Float Display
E = Double Float Display <only for double databases>
A = ASCII Display
1 = DNP Binary Inputs      2 = DNP Binary Outputs
3 = DNP Counters          4 = DNP Analog Inputs
5 = DNP Analog Outputs    6 = DNP Frozen Counters
7 = DNP Float Inputs      8 = DNP Double Inputs
9 = DNP Float Outputs     0 = DNP Double Outputs
B = IED Binary Inputs     C = IED Binary Outputs
G = IED Counters          I = IED Analog Inputs
J = IED Analog Outputs
M = Main Menu
  
```

Viewing Data Type Databases

Press **[D]** from the DNP menu, then hold down the **[Shift]** key and press the / key.

```
DNP DATABASE VIEW MENU
?=Display Menu
S=Show Again
-=Back 5 Pages
P=Previous Page
+=Skip 5 Pages
N=Next Page
D=Word Decimal Display
H=Word Hexadecimal Display
L=Double Word Decimal Display
X=Double Word Hexadecimal Display
F=Float Display
A=ASCII Display

1=Binary Inputs
2=Binary Outputs
3=Counters
4=Analog Inputs
5=Analog Outputs
6=Frozen Counters

M=Main Menu
```

Use the number keys 1 to 6 to select the display of the data type you wish to view. For example, if the '1' key is pressed, the following is displayed:

```
DNP BINARY INPUT DATABASE DISPLAY 0 TO 1 <DECIMAL>
0 0
```

Moving Back Through 5 Pages of Registers

Press **[-]** from the Database View menu to skip back to the previous 500 registers of data.

Viewing the Previous 100 Registers of Data

Press **[P]** from the Database View menu to display the previous 100 registers of data.

Skipping 500 Registers of Data

Hold down **[Shift]** and press **[=]** to skip forward to the next 500 registers of data.

Viewing the Next 100 Registers of Data

Press **[N]** from the Database View menu to select and display the next 100 registers of data.

Viewing Data in Decimal Format

Press **[D]** to display the data on the current page in decimal format.

Viewing Data in Hexadecimal Format

Press **[H]** to display the data on the current page in hexadecimal format.

Viewing Data in Floating Point Format

Press **[F]** from the Database View menu. Use this command to display the data on the current page in floating point format. The program assumes that the values are aligned on even register boundaries. If floating-point values are not aligned as such, they are not displayed properly.

Viewing Data in ASCII (Text) Format

Press **[A]** to display the data on the current page in ASCII format. This is useful for regions of the database that contain ASCII data.

Viewing Data in Double Word Decimal Format

Press **[L]** to display the data on the current page in Double Word Decimal format. This is useful for regions of the database that contain Double Word Decimal data.

Viewing Data in Double Word Hexadecimal Format

Press **[X]** to display the data on the current page in Double Word Hexadecimal format. This is useful for regions of the database that contain Double Word Hexadecimal data.

Viewing DNP Binary Inputs

Press **[1]** to view a list of DNP Binary Inputs.

Viewing DNP Binary Outputs

Press **[2]** to view a list of DNP Binary Outputs.

Viewing DNP Counters

Press **[3]** to view a list of DNP Counters.

Viewing DNP Analog Inputs

Press **[4]** to view a list of DNP Analog Inputs.

Viewing DNP Analog Outputs

Press **[5]** to view a list of DNP Analog Outputs.

Viewing DNP Frozen Counters

Press **[6]** to view a list of DNP Frozen Counters.

Viewing DNP Float Inputs

Press **[7]** to view a list of DNP Float Inputs.

Viewing DNP Float Outputs

Press **[9]** to view a list of DNP Float Outputs.

Returning to the Main Menu

Press **[M]** to return to the Main Menu.

4.1.8 Master Command List Menu

Use this menu to view the command list for the module. Press **[?]** to view a list of commands available on this menu.

```
***** DNP MASTER PORT COMMAND SELECTION MENU *****
PRODUCT = DNP5 REVISION = 1.00 OP SYS REV = 0900 PROD RUN # = 1501
SELECT RANGE OF COMMANDS TO VIEW USING ONE OF THE KEYS INDICATED.
KEY-COMMANDS KEY-COMMANDS KEY-COMMANDS KEY-COMMANDS KEY-COMMANDS
0 - 0-19 1 - 20-39 2 - 40-59 3 - 60-79 4 - 80-99
5 - 100-119 6 - 120-139 7 - 140-159 8 - 160-179 9 - 180-199
A - 200-219 B - 220-239 C - 240-259 D - 260-279 E - 280-299
```

Use keys **[0]** through **[E]** to view each range of commands. The following illustration shows the status of command 0.

```
***** DNP MASTER PORT COMMANDS *****
PRODUCT = DNP5 REVISION = 2.35 OP SYS REV = 1206 PROD RUN # = 1501
COMMAND INFORMATION (FIRST COMMAND INDEX = 0)
CMD PORT DEV PNT POINT DNP IED POLL LAST LAST
NUMB /FLG ADDR OBJ# VAR FUNC ADDR COUNT ADDR ADDR INTU POLL ERROR
0 31 2 12 1 6 0 10 -1 0 0 0 65535
```

Refer to Command List for a description of the fields on this list.

- The Last Poll field is the count timer compared to the user configured poll interval. When the Last Poll value is \geq to the poll interval, the command is ready to execute.
- The Last Error field contains the value 65535 when the next command is being executed. Refer to Command Error Codes (page 138) for an explanation of other values that may appear in this field.

Redisplaying the Current Page

Press **[S]** to display the current page of data.

Viewing the Previous 50 Commands

Press **[-]** to view the previous 50 commands.

Viewing the Previous Page of Commands

Press **[P]** to display the previous page of commands.

Viewing the Next 50 Commands

Press **[+]** to view the next 50 commands from the master command list.

Viewing the Next Page of Commands

Press **[N]** to display the next page of commands.

Returning to the Main Menu

Press **[M]** to return to the Main Menu.

4.1.9 Master Command Error List Menu

Use this menu to view the command error list for the module. Press **[?]** to view a list of commands available on this menu.

```

***** DNP MASTER PORT SLAVE SELECTION MENU *****
PRODUCT = DNP  REVISION = 1.00  OF SYS REV = 0900  PROD RUN # = 1501
SELECT RANGE OF SLAVES TO VIEW USING ONE OF THE KEYS INDICATED.
KEY-SLAVES  KEY-SLAVES  KEY-SLAVES  KEY-SLAVES
0 - 0-9      1 - 10-19    2 - 20-29    3 - 30-39
  
```

Use keys **[0]** through **[3]** to view the command list for each group of slaves. The following illustration shows the status of slaves 0 and 1.

```

***** DNP MASTER PORT SLAVE STATISTICS *****
PRODUCT = DNP  REVISION = 1.00  OF SYS REV = 0900  PROD RUN # = 1501
ERROR COUNTERS FOR EACH DEVICE (FIRST DEVICE = 0)
DEVICE  DEVICE  BAD  BUFFER  TRANSPORT  CONFIRM  CONFIRM  NO APPL.
INDEX  ADDRESS  CRC  OVERFLOW  SEQUENCER  RETRIES  FAILURES  RESPONSE
0      65535    0    0        0          0        0        0
1      2       0    0        0          0        0        0
  
```

Redisplaying the Current Page

Press **[S]** to display the current page of data.

Viewing the Previous 20 Commands

Press **[-]** to display data for the previous 20 commands.

Viewing the Previous Page of Commands

Press **[P]** to display the previous page of commands.

Viewing the Next 20 Commands

Press **[+]** to display data for the next 20 commands.

Viewing the Next Page of Commands

Press **[N]** to display the next page of commands.

Returning to the Main Menu

Press **[M]** to return to the Main Menu.

4.2 LED Status Indicators

The LEDs indicate the module's operating status as follows:

ProSoft Module	Color	Status	Indication
CFG	Green	On	Data is being transferred between the module and a remote terminal using the Configuration/Debug port.
		Off	No data is being transferred on the Configuration/Debug port.
P1	Green	On	Data is being transferred by the module on Port 1.
		Off	No data is being transferred on the port.
P2	Green	On	Data is being transferred by the module on Port 2
		Off	No data is being transferred on the port.
APP	Amber	On	The MVI module is working normally.
		Off	The MVI module program has recognized a communication error on one of its ports.
BP ACT	Amber	On	The LED is on when the module is performing a write operation on the backplane.
		Off	The LED is off when the module is performing a read operation on the backplane. Under normal operation, the LED should blink rapidly on and off.
OK	Red/ Green	Off	The card is not receiving any power and is not securely plugged into the rack.
		Green	The module is operating normally.
		Red	The program has detected an error or is being configured. If the LED remains red for over 10 seconds, the program has probably halted. Power down and remove the card from the rack and re-insert the card, then power up the rack.
BAT	Red	Off	The battery voltage is OK and functioning.
		On	The battery voltage is low or battery is not present. Allow battery to charge by keeping module plugged into rack for 24 hours. If BAT LED still does not go off, contact the factory, as this is not a user serviceable item.

During module configuration, the OK LED will be red and the APP and BP ACT LEDs will be on. If the LEDs are latched in this mode for a long period of time, look at the configuration error words in the configuration request block.

4.3 Clearing a Fault Condition

Typically, if the OK LED on the front of the module turns red for more than ten seconds, a hardware problem has been detected in the module, or the program has exited.

To clear the condition, follow these steps:

- 1 Turn off power to the rack
- 2 Remove the card from the rack
- 3 Verify that all jumpers are set correctly

- 4 If the module requires a Compact Flash card, verify that the card is installed correctly
- 5 Re-insert the card in the rack and turn the power back on
- 6 Verify the configuration data being transferred to the module from the PLC processor.

If the module's OK LED does not turn green, verify that the module is inserted completely into the rack. If this does not cure the problem, contact ProSoft Technology Support.

4.4 Troubleshooting

Use the following troubleshooting steps if you encounter problems when the module is powered up. If these steps do not resolve your problem, please contact ProSoft Technology Technical Support.

Processor Errors

Problem Description	Steps to take
Processor Fault	Verify that the module is plugged into the slot that has been configured for the module. Verify that the slot in the rack configuration has been set up correctly in the ladder logic.
Processor I/O LED flashes	This indicates a problem with backplane communications. Verify that all modules in the rack are configured in the ladder logic.

Module Errors

Problem Description	Steps to take
BP ACT LED remains off or blinks slowly	This indicates that backplane transfer operations are failing. Connect to the module's Configuration/Debug port to check this. To establish backplane communications, verify the following items: <ul style="list-style-type: none"> ▪ The processor is in Run mode. ▪ The backplane driver is loaded in the module. ▪ The module is configured for read and write block data transfer. ▪ The ladder logic handles all read and write block situations. ▪ The module is configured in the processor.
OK LED remains red	The program has halted or a critical error has occurred. Connect to the Configuration/Debug port to see if the module is running. If the program has halted, turn off power to the rack, remove the card from the rack and re-insert the card in the rack, and then restore power to the rack.

5 Reference

In This Chapter

➤ Product Specifications.....	75
➤ Functional Overview.....	78
➤ Designing the system.....	94
➤ Cable Connections.....	111
➤ Collision Avoidance (DNP modules only).....	117
➤ Block Assignments.....	118
➤ DNP Configuration Forms	121
➤ MVI71-DNP Communication Module Configuration	124
➤ Error Status Table	132
➤ Module Error Codes	136
➤ Command Error Codes	138
➤ Event Size Computation.....	140
➤ Device Profile	141
➤ Slave Unit Device Profile Object Subset	142
➤ Master Unit Device Profile Object Subset	150

5.1 Product Specifications

The MVI71 DNP 3.0 Master/Slave Communication Module is a single slot, backplane compatible DNP 3.0 interface solution for the PLC platform. This module provides highly configurable support of both DNP 3.0 Master and Slave implementations (level 2 minimum), allowing the many SCADA and field devices supporting the DNP protocol to be integrated into the powerful PLC platform.

5.1.1 Features and Benefits

The module supports DNP Subset Level 2 features and some of the Level 3 features allowing the many SCADA and field devices supporting the DNP protocol to be integrated into the PLC platform. The module acts as an input/output module between the DNP network and the PLC backplane. The data transfer from the PLC processor is asynchronous from the actions on the DNP network. Databases are user defined and stored in the module to hold the data required by the protocol.

5.1.2 General Specifications

- Single Slot – 1771 backplane compatible
- The module is recognized as an Input/Output module and has access to processor memory for data transfer between processor and module
- Ladder Logic is used for data transfer between module and processor. Sample ladder file included.
- Configuration data obtained from configuration text file downloaded to module. Sample configuration file included.

5.1.3 Hardware Specifications

Specification	Description
Form Factor	Single Slot 1771 chassis compatible BTR/BTW data transfer Local or remote rack
Backplane current load	800 mA @ 5 V
Operating temperature	0 to 60°C (32 to 140°F)
Storage temperature	-40 to 85°C (-40 to 185°F)
Shock	30g operational 50g non-operational
Vibration	5 g from 10150 Hz
Relative humidity	5% to 95% (non-condensing)
LED Indicators	Module status Backplane transfer status Application status Serial activity and error LED status
Debug/Configuration port (CFG)	
CFG Port (P1)	RJ45 (DB-9M with supplied cable) RS-232 only
Configuration Connector	RJ45 RS-232 Connector (RJ45 to DB-9 cable shipped with unit)
Application Ports	
Application Serial port (P2, P3) (Serial Modules)	Two RJ45 RS-232/422/485 Application ports

5.1.4 Functional Specifications

The module has two DNP protocol ports that can be user configured to operate in a Master/Slave or in a Slave/Slave redundant port configuration.

User defined internal register space is accessible to the protocol driver and to the PLC processor memory.

DNP 3.0 Slave Protocol Specifications

The DNP Slave port(s) accepts DNP commands to control and monitor data stored in the module's DNP Slave databases. If a DNP Master port is also configured, a portion of these slave databases can be derived from or can control IED devices connected to the DNP master port.

- Report-by-Exception data is logged to the module's database
- Supports unsolicited messaging
- Each DNP point type is user configurable by point
- Class assignments are completely user-definable on a Type and point basis (BI, AI, FI point types)
- Supports clock synchronization from a master or from the processor
- Up to 400 events are stored for Floats, Binary In and Analog In Inputs
- Collision avoidance algorithm per DNP organization for redundant port switching (redundant slave mode)
- Special modem AT command string and timing support for dialing out on redundant port (redundant slave mode)

DNP 3.0 Master Protocol Specifications

The DNP 3.0 Master port can be configured as a virtual DNP Master device that actively issues user-defined DNP commands to nodes on the network.

- The Master port supports 300 user defined commands, each one containing its own set of data link and application layer characteristics
- Master port logically supports up to 40 slave devices
- Individual command configuration includes conditional or continuous polling and Poll Delay Time
- Slave status and Command status available for transfer to the processor
- Event data received from the slave devices updates the module database (Date and Time stamping is not stored or used by module)
- Special command handling for Digital Output CROB under processor control for pulse output control

DNP 3.0 ports (PRT1 & PRT2)

- User-definable module memory usage
- Full radio, modem and multi-drop support
- Support for the storage and transfer of all DNP data types across the backplane
- Communication parameters
 - Address: 0 to 65534 (slave mode)
 - Baud rate: 110 to 115K
 - Parity: none, data bits: 8, Stop bit: 1
 - RTS on delay: 0 to 65535 milliseconds
 - RTS off delay: 0 to 65535 milliseconds

5.2 Functional Overview

This section provides an overview of how the MVI71-DNP module transfers data using the DNP protocol. You should understand the important concepts in this chapter before you begin installing and configuring the module.

5.2.1 General Concepts

The following topics describe several concepts that are important for understanding the operation of the MVI71-DNP module.

- 1 On power up the module begins performing the following logical functions:
- 2 Initialize hardware components
 - Initialize PLC backplane driver
 - Test and Clear all RAM
 - Initialize the serial communication ports
- 3 Reads configuration from the DNP.CFG file
- 4 Allocate and initialize Module Register space
- 5 Enable Slave Driver on selected ports
- 6 Enable Master Driver on selected port if configured

After the module has received the Module Configuration, the module will begin communicating with other nodes on the network, depending on the configuration.

Module Power Up and Configuration

Configuration information is stored on the module's Compact Flash. Setup of the module requires software configuration using the RSLogix 5 program and the DNP.CFG configuration file on the Compact Flash. The easiest method to implement the module is to start with the example provided with the module (MVI71DNP.RSP) and the example configuration file (DNP.CFG). Module Configuration describes how to use and/or modify the two files.

If the DNP master port is to be used, the module reads the slave configuration information and builds the slave list during the configuration process. The module also reads the command list from the .CFG file. Valid commands will be added to the command list. Binary input, counter and analog input objects will be added to the point lists for each slave based on the commands processed. In addition, the RBE (Report By Exception) flags for the binary and analog input points are set in the RBE flag database.

The module next checks the DNP BO/AO (Binary Output / Analog Output) preset flag to determine if the DNP binary and analog output data must be read from the PLC. The option permits the PLC to set these read-only data at startup. There is no static memory available on the module to remember the last values for these data types. In order to prevent "shock" to the system at boot time, this option can be used to set the module's database to the last transferred set of data. Ladder logic must transfer the data to the module using BTR/BTW instructions for these data types.

The module now checks the IED (Intelligent Electronic Device) BI/AI/C (Binary Input / Analog Input / Counter) preset flag to determine if the IED binary and analog input and counter data must be read from the PLC. The option permits the PLC to set these read-only data at startup. There is no static memory available on the module to remember the last values for these data types. In order to prevent "shock" to the system at boot time, this option can be used to set the module's database to the last transferred set of data. Ladder logic must transfer the data to the module using the BTR/BTW instructions for these data types.

Main Logic Loop

Upon completing the power up configuration process, the module enters an infinite loop that performs the following functions:

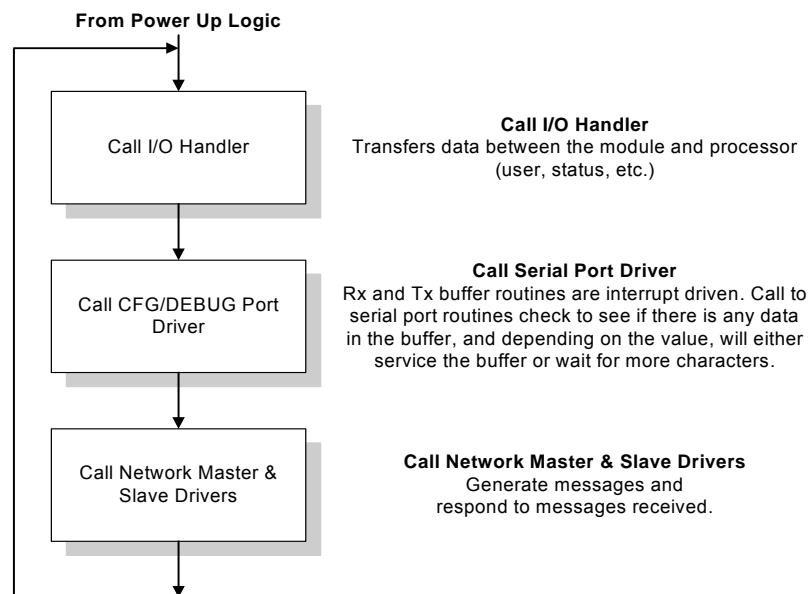

Backplane Data Transfer

The MVI71-DNP module communicates directly over the PLC backplane. Data is paged between the module and the PLC processor across the backplane using BTR and BTW operations. Data is transferred from the module to the processor using the BTR blocks, and data is transferred from the processor to the module using BTW blocks.

The following illustration shows the data transfer method used to move data between the PLC processor, the MVI71-DNP module, and the DNP network.

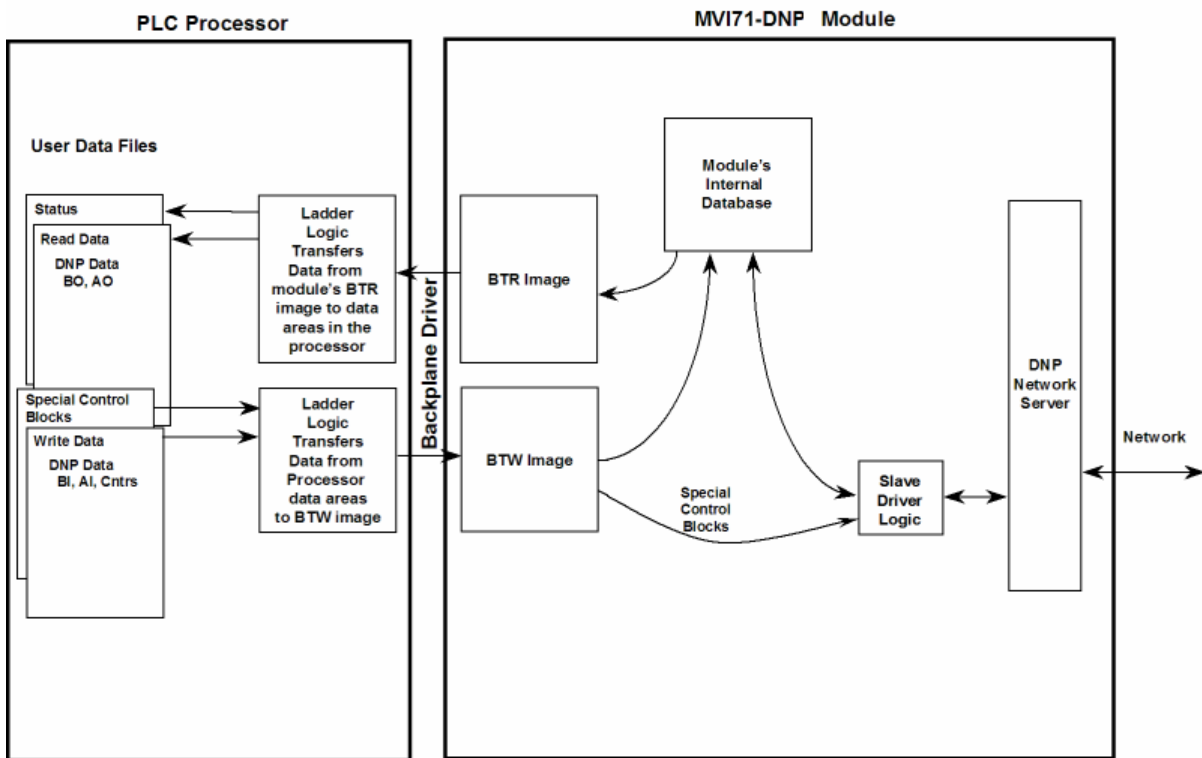

As shown in the diagram above, all data transferred between the module and the processor over the backplane is through the BTR and BTW blocks. Ladder logic must be written in the PLC processor to interface the block data with user data files. All data used by the module is stored in its internal databases. These databases are defined as virtual DNP data tables with addresses from 0 to the maximum number of points for each data type. The following illustration shows the layout of the databases:

DATA AREA	BLOCKS		
DNP DATA	BINARY INPUTS	PLC DATA	0 to 15
		IED DATA	
	BINARY OUTPUTS	PLC DATA	20 to 35
		IED DATA	
	COUNTER DATA	PLC DATA	40 to 55
		IED DATA	
	ANALOG INPUTS	PLC DATA	60 to 75
		IED DATA	
	ANALOG OUTPUTS	PLC DATA	80 to 95
		IED DATA	
	FLOAT INPUTS	PLC DATA	1100 to 1107

DATA AREA	BLOCKS		
	FLOAT OUTPUTS	PLC DATA	1140 to 1147
	FROZEN COUNTER DATA		
	BINARY INPUT EVENTS		
	ANALOG INPUT EVENTS		
	FLOAT INPUT EVENTS		
LAST VALUE DATA	BINARY INPUTS		
	ANALOG INPUTS		
	FLOAT INPUTS		
	DNP BINARY OUTPUTS		
	DNP ANALOG OUTPUTS		
	IED BINARY OUTPUTS		
	IED ANALOG OUTPUTS		
IED DATA	BINARY INPUTS		1000 to 1015
	BINARY OUTPUTS		1020 to 1035
	COUNTER DATA		1040 to 1055
	ANALOG INPUTS		1060 to 1075
	ANALOG OUTPUTS		1080 to 1095
RBE FLAGS	BINARY INPUT		
	ANALOG INPUT		

Data contained in this database is paged through the BTR and BTW images by coordination of the PLC ladder logic and the MVI71-DNP module's program. Up to 64 words of data can be transferred from the module to the processor at a time. Up to 64 words of data can be transferred from the processor to the module.

Each block transferred from the module to the processor or from the processor to the module contains a block identification code that describes the content of the block. The following table defines the blocks used by this module:

Data Type	Start Block #	Max Block #	Max # of Points
Digital Input	0	15	15360
Digital Output	20	35	15360
Counters	40	55	480
Analog Input	60	75	960
Analog Output	80	95	960
IED Digital Input	1000	1015	15360
IED Digital Output	1020	1035	15360
IED Counters	1040	1055	480

Data Type	Start Block #	Max Block #	Max # of Points
IED Analog Input	1060	1075	960
IED Analog Output	1080	1095	960
Float Input	1100	1107	240
Float Output	1140	1147	240

Reserved Block Numbers

Block Number	Function/Description
249 or 9949	Read Slave Communication Error Table block
250 or 9950	Read Command Error List Block
251	DNP Slave Status/Error Block from module
252	DNP Error List Block from module
253 or 9999	Cold Boot Request from PLC (Block contains no data)
254	Dummy Block: Used by module when no data is to be transferred
255 or 9998	Warm Boot Request
258 or 9958	PLC Binary Input Event data (FUTURE)
259 or 9959	PLC Analog Input Event Data (FUTURE)
270 or 9970	Set PLC time using module's DNP time
271 or 9971	Set module's time using PLC time
297 or 9901	CROB Control Block for Digital Outputs
299 or 9902	Command Control Block (Add command to Command List Queue)
9903	Event message block from module to processor (Master Driver)

Blocks 1 through 149 transfer data between the module and the processor. Blocks 1000 to 1148 transfer the initial output databases (binary and analog output data) from the processor to the module at startup. Blocks 9958 to 9999 are used for command control of the module. Each group of blocks are described in the following topics.

Module DNP Protocol Operation

Unsolicited Messaging

If the module is configured for unsolicited messaging, the module immediately sends an unsolicited response out Port 1 (Primary DNP port) informing the master of a module restart. The module will not log events or process any data read operations from the master until the master clears the restart IIN data bit. The master must also synchronize the time with the module before events are generated if the module is so configured. The master is also responsible for enabling the unsolicited message facility in the module by sending the Enable Unsolicited Messaging command to the module.

Solicited Messaging

If the module is not configured for unsolicited messaging, the program listens on Port 1 for DNP messages from a DNP master and sends responses to requests after initialization. The DNP master must clear the restart IIN bit before the module starts logging events. The master must also synchronize the time with the module before events are generated if the module is so configured.

If the DNP master port is used, the port starts processing the command list. It sends commands and requests out the port to slave units. Data acquired is placed in the correct database in the module. Event messages received from the IED units are placed directly in the event buffer or the values are placed in the database. The communication statistics for each slave unit is tracked by the module and is available for the PLC to request.

While the program is running, a status/error table is maintained. This data is automatically passed to the PLC at a frequency set in the configuration. Refer to the following section on the contents of the table.

If an error is encountered in the module's program, it is logged to the error list maintained by the system. The program maintains a list of the last 60 errors. This data is automatically passed to the PLC at a frequency set in the configuration. Refer to the following section on the error codes contained in the list.

If the module is configured to use the secondary slave DNP port (Port 2), the module may automatically switch communications to that port under the following conditions:

- If the module receives a request on the port from the master
- If unsolicited messages are enabled and the module is configured to switch to the port if application confirm messages are not received while using the primary port (user sets the number of retries in the configuration)

Communications will switch back to the primary DNP port when the module receives a message on that port. If the module restarts, communications will always be attempted on the primary DNP port first.

Normal Data Transfer

Normal data transfer includes the paging of the user data found in the module's internal databases between the module and the controller. These data are transferred through read (BTR) and write (BTW) blocks. Refer to the **Module Configuration** section for a description of the data objects used with the blocks and the ladder logic required. Each data block transferred between the module and the processor has a specific block identification code that defines the data set contained in the block. The following illustration shows the direction of movement of the DNP data types between the module and the processor:

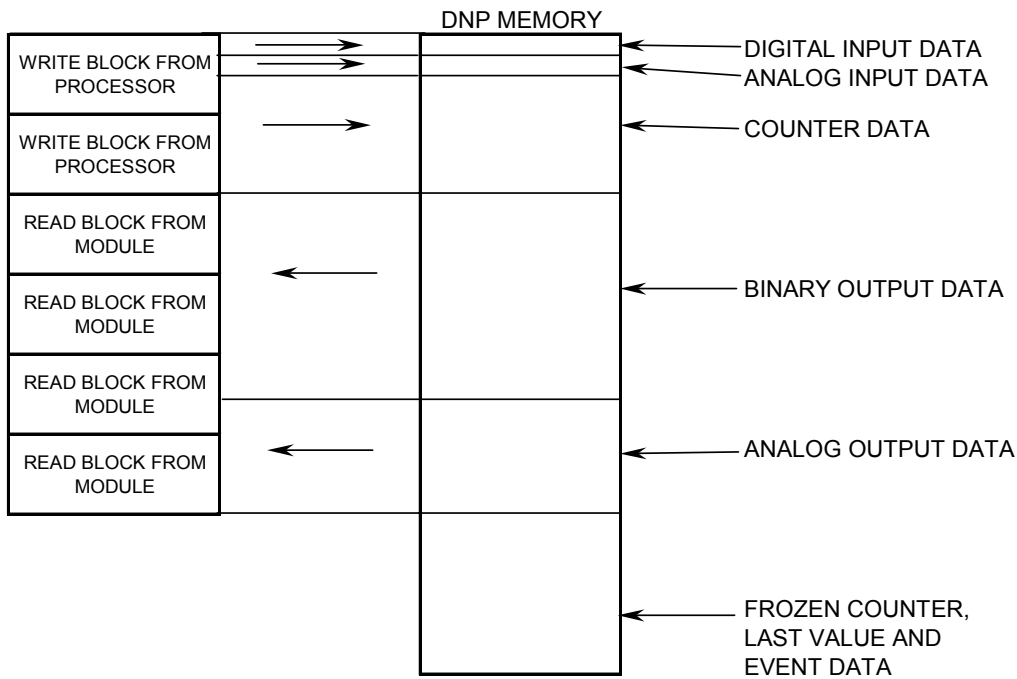

The structure and function of each block is described in the following topics:

Read Block

These blocks of data transfer information from the module to the PLC processor. The structure of the BTR image used to transfer this data is shown in the following table:

Block Offset	Content
0	Read block ID
1	Write block ID
2 to 61	Read data
62 to 63	Spare (Not used)

The Read Block ID is an index value used to determine the location of where the data will be placed in the PLC processor user data file. Each transfer can move up to 60 words (block offsets 2 to 61) of data.

The Write Block ID associated with the block requests data from the PLC processor. Under normal, program operation, the module sequentially sends read blocks and requests write blocks. For example, if two blocks of read data and three blocks of write data are to be moved between the module and the processor, the sequence will be as follows:

R1W1→R2W2→R1W3→R2W1→R1W2→R2W3→R1W1→

This sequence will continue until interrupted by other write block numbers sent by the controller or by a command request from a node on the DNP network or operator control through the module's Configuration/Debug port.

Write Block

These blocks of data transfer information from the PLC processor to the module. The structure of the BTW image used to transfer this data is shown in the following table:

Block Offset	Content
0	Write block ID
1 to 60	Write data
61 to 63	Spare (Not used)

The Write Block ID is an index value used to determine the location in the module's database where the data will be placed. Each transfer can move up to 60 words (block offsets 1 to 60) of data.

Command Control Blocks

Command control blocks are special blocks used to control the module or request special data from the module. The current version of the software supports several command control blocks each of which is discussed in the following topics.

Block 9958 or 258 – PLC Binary Input Event

If the PLC sends a block 9958, the module will place the binary input event data in the block into the event buffer and alter the data values for the points in the DNP binary input database. The format for the event message is shown in the following table.

Word Offset in Block	Data Field(s)	Description
0	Block ID	This field contains the value of 9958 identifying the event block to the module.
1	Event Count	This field contains the number of events contained in the block. Valid values for this field are 1 to 12.
2	Sequence Counter	This field holds the sequence counter for each 9958 block transfer. This synchronizes and confirms receipt of the block by the module.
3	DNP Binary Input Data point	This is the data point in the DNP binary input database represented by the event.
4	Month/Day/State	Formatted: bits 0 to 4 = Day, bits 8 to 11 = Month, bit 15 = digital state for point. All other bits are ignored.

Word Offset in Block	Data Field(s)	Description
5	Hour/Minute	Formatted: bits 0 to 5 = Minutes, bits 8 to 12 = Hour. All other bits are ignored.
6	Sec/Millisecond	Formatted: bits 0 to 9 = Milliseconds, bits 10 to 15 = Seconds.
7	Year	This is the four digit year for the event.
8 to 12		Five words of data for Event #2.
13 to 17		Five words of data for Event #3.
18 to 22		Five words of data for Event #4.
23 to 27		Five words of data for Event #5.
28 to 32		Five words of data for Event #6.
33 to 37		Five words of data for Event #7.
38 to 42		Five words of data for Event #8.
43 to 47		Five words of data for Event #9.
48 to 52		Five words of data for Event #10.
53 to 57		Five words of data for Event #11.
58 to 62		Five words of data for Event #12.
63	Spare	Not Used

Up to 12 events can be passed from the PLC to the module in each block. To ensure that the block reached the module and was processed, the module will send a response read block 9958 to the PLC. The format of the block is shown in the following table.

Word Offset in Block	Data Field(s)	Description
0	Block ID	Identification code for block set to 9958.
1	Block ID	Block identification code for request from PLC by the module.
2	Event Count	This field contains the number of events processed by the module.
3	Sequence Counter	This field contains the sequence counter of the last successful block 9958 received.
4 to 63	Spare	Not used

The sequence counter field in the returned block is set to the last successfully processed block 9958 from the PLC. Compare this value to that sent by the PLC. If the values match, the events can be removed from the PLC. If the values do not match, or the PLC does not receive a 9958 block, the PLC must re-send the block.

Block 9959 or 259 – PLC Analog Input Event

If the PLC sends a block 9959, the module will place the analog input event data in the block into the event buffer and alter the data values for the points in the DNP analog input database. The format for the event message is shown in the following table.

Word Offset in Block	Data Field(s)	Description
0	Block ID	This field contains the value of 9959 identifying the event block to the module.
1	Event Count	This field contains the number of events contained in the block. Valid values for this field are 1 to 10.
2	Sequence Counter	This field holds the sequence counter for each 9959 block transfer. This synchronizes and confirms receipt of the block by the module.
3	DNP Analog Input Data point	This is the data point in the DNP analog input database represented by the event.
4	Analog Input Value	This is the new analog input value represented in the event.
5	Month/Day	Formatted: bits 0 to 4 = Day, bits 8 to 11 = Month. All other bits are ignored.
6	Hour/Minute	Formatted: bits 0 to 5 = Minutes, bits 8 to 12 = Hour. All other bits are ignored.
7	Sec/Millisecond	Formatted: bits 0 to 9 = Milliseconds, bits 10 to 15 = Seconds.
8	Year	Four digit year value for event.
9 to 14		Six words of data for Event #2.
15 to 20		Six words of data for Event #3.
21 to 26		Six words of data for Event #4.
27 to 32		Six words of data for Event #5.
33 to 38		Six words of data for Event #6.
39 to 44		Six words of data for Event #7.
45 to 50		Six words of data for Event #8.
51 to 56		Six words of data for Event #9.
57 to 62		Six words of data for Event #10.
63	Spare	Not Used

Up to 10 events can be passed from the PLC to the module in each block. To ensure that the block reached the module and was processed, the module will send a response read block 9959 to the PLC. The format of the block is shown in the following table.

Word Offset in Block	Data Field(s)	Description
0	Block ID	Identification code for block set to 9959.
1	Block ID	Block identification code for request from PLC by the module.
2	Event Count	This field contains the number of events processed by the module.
3	Sequence Counter	This field contains the sequence counter of the last successful block 9959 received.
4 to 63	Spare	Not used

The sequence counter field in the returned block is set to the last successfully processed block 9959 from the PLC. Compare this value to that sent by the PLC. If the values match, the events can be removed from the PLC. If the values do not match, or the PLC does not receive a 9959 block, the PLC must re-send the block.

Block 9970 or 270 – Set PLC Time Using Module Time

This block transfers the module's time to the PLC processor. Ladder logic must be used to set the processor's clock using the data received. The format of the block sent from the PLC has the following format:

Word Offset in Block	Data Field(s)	Description
0	Block ID	This field contains the value of 9970 identifying the block type to the module.
1 to 63	Not Used	Not Used

The module responds to the request with a read block 9970 with the following format:

Word Offset in Block	Data Field(s)	Description
0	Block Read ID	This field contains the block identification code of 9970 for the block.
1	Block Write ID	This is the next block requested by the module.
2	Year	This field contains the four-digit year to be used with the new time value.
3	Month	This field contains the month value for the new time. Valid entry for this field is in the range of 1 to 12.
4	Day	This field contains the day value for the new time. Valid entry for this field is in the range of 1 to 31.
5	Hour	This field contains the hour value for the new time. Valid entry for this field is in the range of 0 to 23.
6	Minute	This field contains the minute value for the new time. Valid entry for this field is in the range of 0 to 59.
7	Seconds	This field contains the second value for the new time. Valid entry for this field is in the range of 0 to 59.
8	Milliseconds	This field contains the millisecond value for the new time. Valid entry for this field is in the range of 0 to 999.
9	Remote Time Synchronization	This field informs the PLC if the date and time passed has been synchronized with a remote DNP master device on the module's slave port.
10 to 63	Not Used	Not Used

Block 9971 or 271 – Set Module's Time Using PLC Time

This block sets the clock in the module to match the clock in the PLC processor. If the PLC sends a block 9971, the module will set its time using the data contained the block. The format of the block is shown in the following table:

Word Offset in Block	Data Field(s)	Description
0	Block ID	This field contains the block identification code of 9971 for the block.
1	Year	This field contains the four-digit year to be used with the new time value.
2	Month	This field contains the month value for the new time. Valid entry for this field is in the range of 1 to 12.
3	Day	This field contains the day value for the new time. Valid entry for this field is in the range of 1 to 31.
4	Hour	This field contains the hour value for the new time. Valid entry for this field is in the range of 0 to 23.
5	Minute	This field contains the minute value for the new time. Valid entry for this field is in the range of 0 to 59.
6	Seconds	This field contains the second value for the new time. Valid entry for this field is in the range of 0 to 59.
7	Milliseconds	This field contains the millisecond value for the new time. Valid entry for this field is in the range of 0 to 999.
8 to 63	Not Used	Not Used

The module responds to a valid 9971 block with a read block of the following format:

Word Offset in Block	Data Field(s)	Description
0	Block Read ID	This field contains the block identification code of 9971 for the block.
1	Block Write ID	This is the next block requested by the module.
2 to 63	Not Used	Not Used

Block 9998 or 255 – Warm Boot Module

If the PLC sends a block number 9998, the module performs a warm-boot operation.

Block 9999 or 253 – Cold Boot Module

If the PLC sends a block number 9999, the application will perform the cold-boot operation. The module exits the program and performs a soft restart on the module.

Side-Connect Backplane Data Transfer

The side-connect interface is the simplest method to implement the module. No ladder logic is required for the interface because the driver handles data movement between the module and the processor automatically. The data flow associated with this interface is shown in the following diagram:

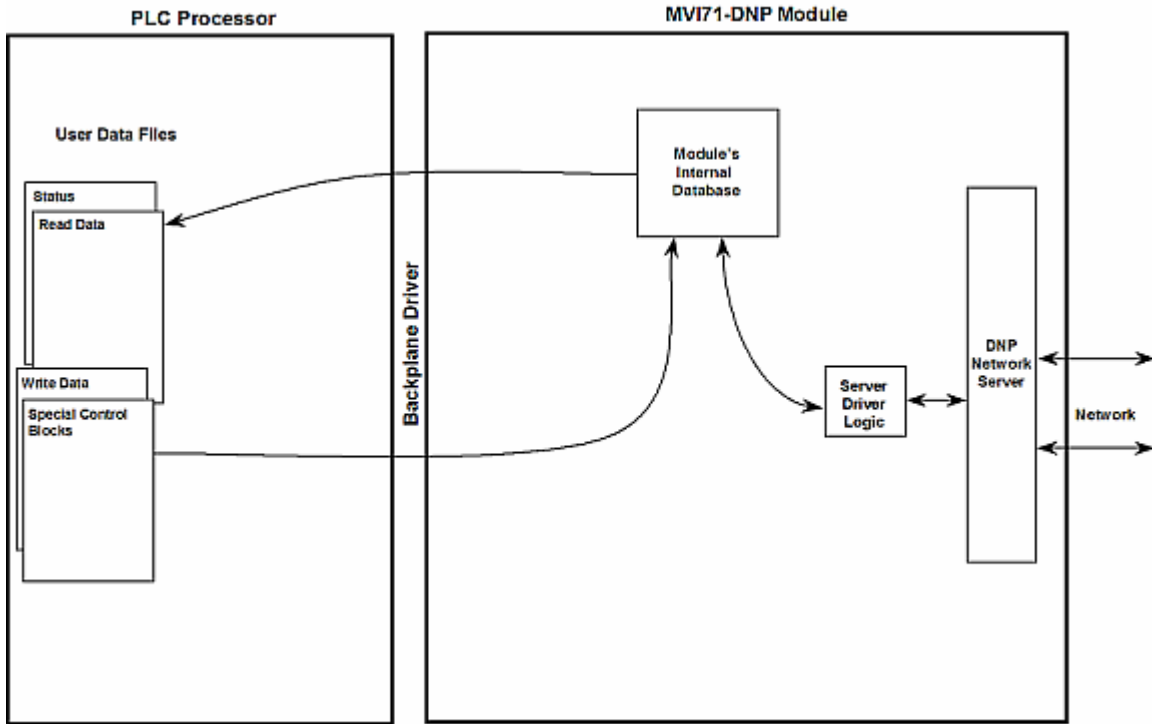

The configuration information for the module determines the size of the read and write data areas and the locations of these data sets in the module's internal database. Therefore, to use this interface, just set up the files required by the module. The following table lists the files required for the side-connect interface:

File Number	Example	Size	Description
Cfg File	N10	100	Control/Status File
Cfg File+1	N11	to 1000	Data transferred from the module to the processor Other files for read data
Cfg File+1+n	N12	to 1000	Data transferred from the processor to the module
Cfg File+1+n+m			Other files for write data

n is the number of read data files minus one.

Side-Connect Interface File List

Cfg+#	File #	File Size	Description
0	N	150	Command control data starting at offset 80 (80 to 143 data area)
1	N		Reserved
2	N	124	Error/Status and Error List data destination

Cfg+#	File #	File Size	Description
3	N	(960 max)	Digital input data source
4	N	(960 max)	Digital output data source
5	N	(960 max)	Counter data source and destination
6	N	(960 max)	Analog input data source
7	N	(960 max)	Analog output data destination
8	N	(960 max)	IED digital input data destination
9	N	(960 max)	IED digital output data source
10	N	(960 max)	IED counter data destination
11	N	(960 max)	IED analog input data destination
12	N	(960 max)	IED analog output data source
13	F	(240 max)	DNP slave floating-point input data
14	N		Reserved
15	F	(240 max)	DNP slave floating-point output data
16	N		Reserved

5.2.2 Data Flow Between MVI71-DNP Module and PLC Processor

The following topics describe the flow of data between the two pieces of hardware (PLC processor and MVI71-DNP module) and other nodes on the DNP network under the module's different operating modes. Each port on the module is configured to emulate a DNP master device or a DNP slave device. The operation of each port is dependent on this configuration. The following topics discuss the operation of each mode.

Slave Driver

The Slave Driver Mode allows the MVI71-DNP module to respond to data read and write commands issued by a master on the DNP network. The following flow chart and associated table describe the flow of data into and out of the module.

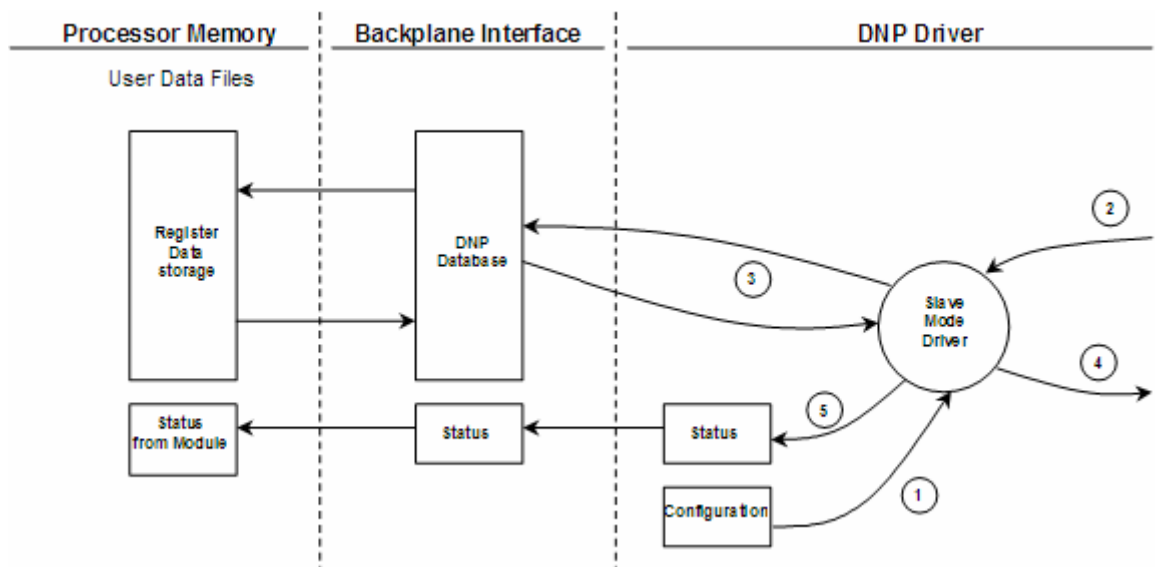

Step	Description
1	The DNP slave port driver receives the configuration information from the DNP.CFG file. This information configures the serial port and define the slave node characteristics. Additionally, the configuration information contains data that can be used to offset data in the database to addresses requested in messages received from master units.
2	A Host device (DNP Master unit) issues a read or write command to the module's node address. The port driver qualifies the message before accepting it into the module.
3	After the module accepts the command, the data is immediately transferred to or from the appropriate internal database in the module. If the command is a read command, the data is read out of the database and a response message is built. If the command is a write command, the data is written directly into the database and a response message is built.
4	After the data processing has been completed in Step 3, the response is issued to the originating master node.
5	Counters are available in the Status Block that permit the ladder logic program to determine the level of activity of the Slave Driver.

Review the Installing and Configuring the Module section for a complete list of the parameters that must be defined for a slave port. The response messages from the slave driver include an IIN (internal indication word) defined in the Reference chapter – Internal Indication Word.

The slave driver supports object 110 (octet string data). Four points are pre-assigned values as defined in the following table.

Point #	Description
0	Module Name as assigned in configuration file.
1	Product Name
2	Version Information in format: www xxx yy zz Where www is product code, xxx is the revision, yy is the operating system number, and zz is the run number.
3	Manufacturer name for module.

The variation used in the request message determines the length of the string returned for each point. The maximum string length used by the module is 100.

Master Driver Mode

In the Master mode, the MVI71-DNP module issues read or write commands to slave devices on the DNP network. These commands are user configured in the module via the Master Command List received from the DNP.CFG file.

Command status is returned to the processor for each individual command in the command list status block. The following flow chart and associated table describe the flow of data into and out of the module.

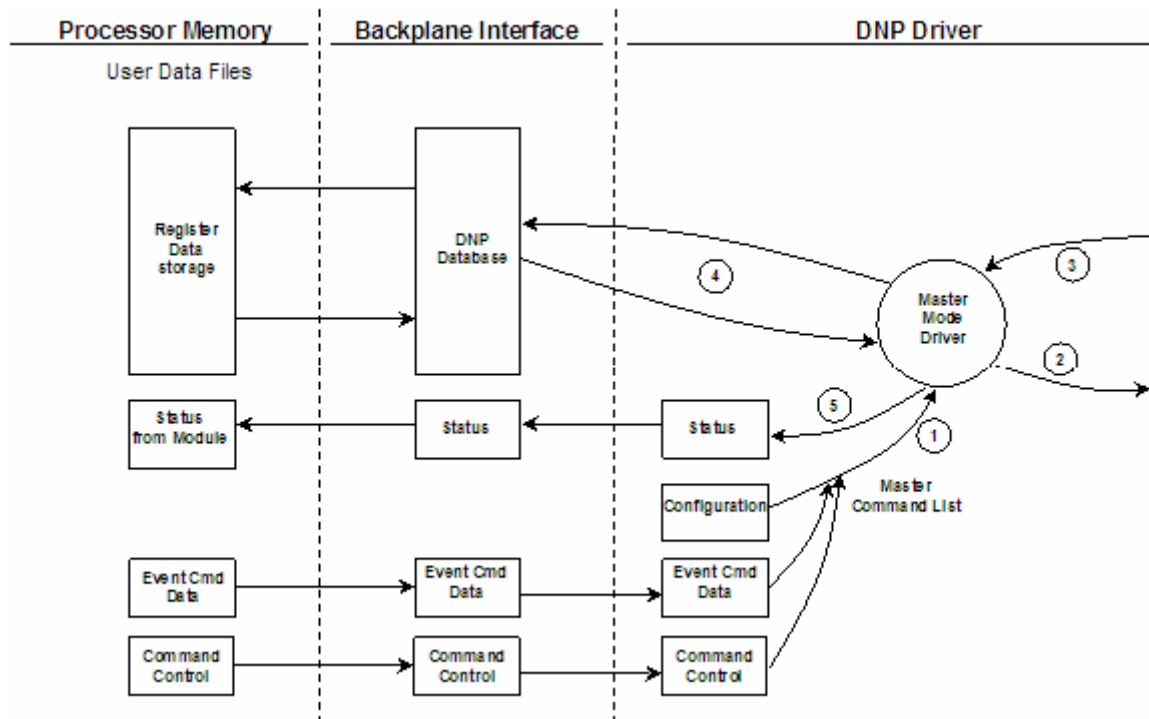

Step	Description
1	The Master driver obtains configuration data from the DNP.CFG file. The configuration data obtained includes the Master Slave and Command Lists. These values are used by the Master driver to determine the type of commands to be issued to the other nodes on the DNP network (Refer to the MVI71-DNP Module Set Up Guide).
2	After configuration, the Master driver begins transmitting read and/or write commands to the other nodes on the network. If writing data to another node, the data for the write command is obtained from one of the module's internal databases to build the command.
3	Presuming successful processing by the node specified in the command, a response message is received into the Master driver for processing.
4	Data received from the node on the network is passed into the module's appropriate internal database, assuming a read command.
5	Status is returned to the PLC processor for each command in the Master Command List.

Refer to the Installing and Configuring the Module section for a complete description of the parameters required to define the virtual DNP master port

5.3 Designing the system

System design defines the data requirements of the system, communication parameters, and module functionality. The application developer should refer to the person responsible for the DNP master and slave device configurations to be certain the functionality and data types required for the whole system are consistent. Review the DNP Device Profile and DNP Subset documentation for a definition of the level of DNP support offered by the module.

The following topics describe each element of system design.

5.3.1 System Design Considerations

In order to implement a solution using the module, the PLC must be set up using both program and data files. The data transfer interface requires ladder logic in order to interface data in the module with that in the PLC. Data is transferred between the module and the PLC through BTR and BTW instructions. These data areas are shared data regions available to both the processor and the module. The ladder logic required is discussed in the ladder logic section. This program interacts with the module by sending and receiving data.

Before you generate the program or layout the data files, you must first design your system. Time spent doing system design at the outset of the project will greatly enhance the success and ease of development of the project.

DNP Functionality Review

This phase of design defines the features of the DNP Level 2 Subset supported by the module and to be utilized in the specific application. For example, will the unit use unsolicited messaging? Coordination with the DNP master developer is required to be certain the host will support the functionality you select. If a DNP master port is to be used, the parameters required to communicate with the slave devices must be known and considered in installing and configuring the module.

The features that must be defined in this design step are as follows:

Mode	DNP Feature	Discussion
Slave	Is collision avoidance required for the primary DNP port?	Collision avoidance is required when unsolicited messaging is used. Any node on the network (master or slave) can transmit a message when data is ready. Collision avoidance prevents two or more units from transmitting data at the same time. This feature requires special cabling and timing considerations. It will only operate in RS-232 mode, and is not supported in RS-485 or RS-422 modes.
Slave	Will the module use events and the Report by Exception feature?	If the DNP Slave driver will generate event messages, they must be retrieved from the module using class polls or polls for the specific event objects. Refer to Event Size Computation for computing event size for digital and analog inputs.
Slave	Will analog events be returned with or without a time value?	The default for analog events is to return them without time. This is as specified in the DNP Subset document. The module supports analog event reporting with time. This is selected setting bit 5 in the configuration word (offset 21) for the module.

Mode	DNP Feature	Discussion
Slave	Will events be logged before time synchronization has occurred?	This feature will avoid logging events without the proper date and time stamping. When the DNP slave driver is initialized, it will have the IIN bit set to request time synchronization from the remote master unit. The master must synchronize the time before the module will generate events. This feature is selected using bit 8 in the module's configuration word.
Slave	Will unsolicited messages be used? If so, how may for each class before triggering and what is the delay time?	Unsolicited messaging provides the means for a slave unit to send event data asynchronously to the master unit without a request from the master. This requires the use of collision avoidance to prevent two or more units from transmitting data on the network at one time.
Slave	Will the module use the secondary DNP Slave port?	The secondary DNP slave port on the module is a backup port to the primary slave port. Only one port can be used at any one time. The module supports automatic switching between the two ports based on several factors.
Master	Will the module use the DNP Master port?	The module can be configured as a DNP master unit to interface with DNP slave (IED) units. This feature requires configuration of the communication characteristics for each slave and the definition of a command list. The command list polls the slave units and to map the data from the IED units to the databases contained in the module.
Master & Slave	What will be the memory mapping for the DNP and IED memory areas?	There are many databases maintained within the module for all the specific DNP data types and for the virtual master and slave unit simulated in the module. For successful application of the module, an understanding of the databases is required to carefully design them.
Slave	Will the secondary DNP port have a dial-up modem attached?	The secondary DNP slave port on the module can be configured to have a dial-up modem attached. Use of this feature requires bit 2 be set in the configuration word. Additionally, many aspects of the modem timing features must also be configured.

5.3.2 Data Requirements

This design phase defines what data elements are to be interfaced in the PLC with the DNP master and slave. The module provides the following data types:

- digital input and output
- counter
- analog input and output
- Floating-Point

All communications between the DNP master and the PLC is through these data types. Therefore, all data to be used by the system must be contained and configured in one of these data types.

The following illustration shows the databases maintained by the module for the DNP and IED data.

DNP DATA	BINARY INPUTS	PLC DATA
		IED DATA
	BINARY OUTPUTS	PLC DATA
		IED DATA
	COUNTER DATA	PLC DATA
		IED DATA
	ANALOG INPUTS	PLC DATA
		IED DATA
	ANALOG OUTPUTS	PLC DATA
		IED DATA
	FLOAT INPUTS	PLC Data
	FROZEN COUNTER DATA	
	BINARY INPUT EVENTS	
ANALOG INPUT EVENTS		
FLOAT INPUT EVENTS		
LAST VALUE DATA	BINARY INPUTS	
	ANALOG INPUTS	
	FLOAT INPUTS	
	DNP BIN OUTPUTS	
	DNP ANALOG OUTPUTS	
	IED BIN OUTPUTS	
	IED ANALOG OUTPUTS	
IED DATA	BINARY INPUTS	
	BINARY OUTPUTS	
	COUNTER DATA	
	ANALOG INPUTS	
	ANALOG OUTPUTS	
RBE FLAGS	BINARY INPUT	
	ANALOG INPUT	

The module is responsible for maintaining the databases using data acquired from the PLC IED units attached to the DNP master port and DNP master attached to the DNP slave port.

The following illustration shows the interaction of the binary and analog input points with the databases.

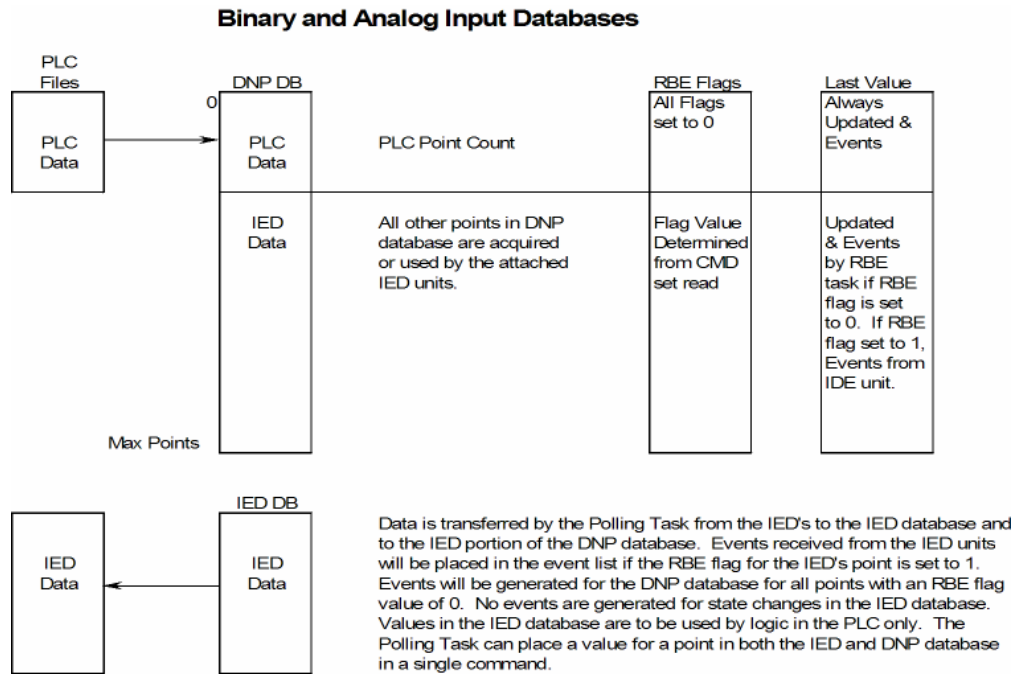

The DNP database consists of data from the PLC and the IED units. The IED database contains only data acquired from IED units. This data can be used in the PLC's ladder logic, and is the only path to get IED data into the PLC. The RBE flags and last value database are used for event generation. Events received from the IED unit can be placed directly in the event buffer. This requires that the RBE flag for the data points be set to a value of 1. For all points in the RBE flags database with a value of zero, the module will generate the events.

The following illustration shows the interaction of the counter points with the databases.

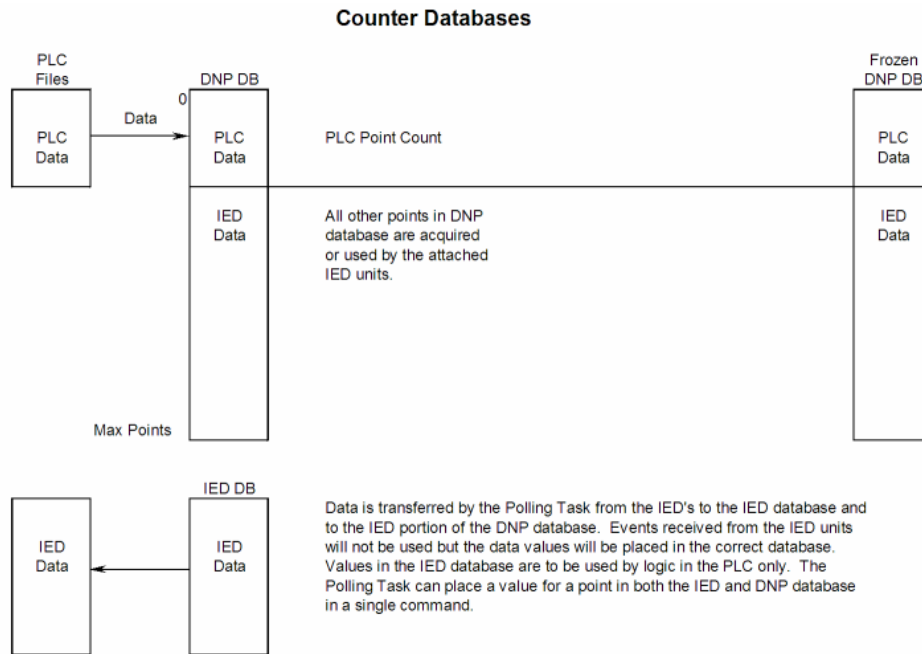

The DNP database consists of data from the PLC and the IED units. The IED database contains only data acquired from IED units. You can use this data in the PLC's ladder logic. When the DNP slave port receives a counter freeze command, the current counter values are passed to the frozen counter database. If the DNP slave port receives a counter freeze with reset command, the current counter values will be passed to the frozen counter database and only the values in the DNP counter database will be set to 0.

The following illustration shows the interaction of the binary and analog output points with the databases.

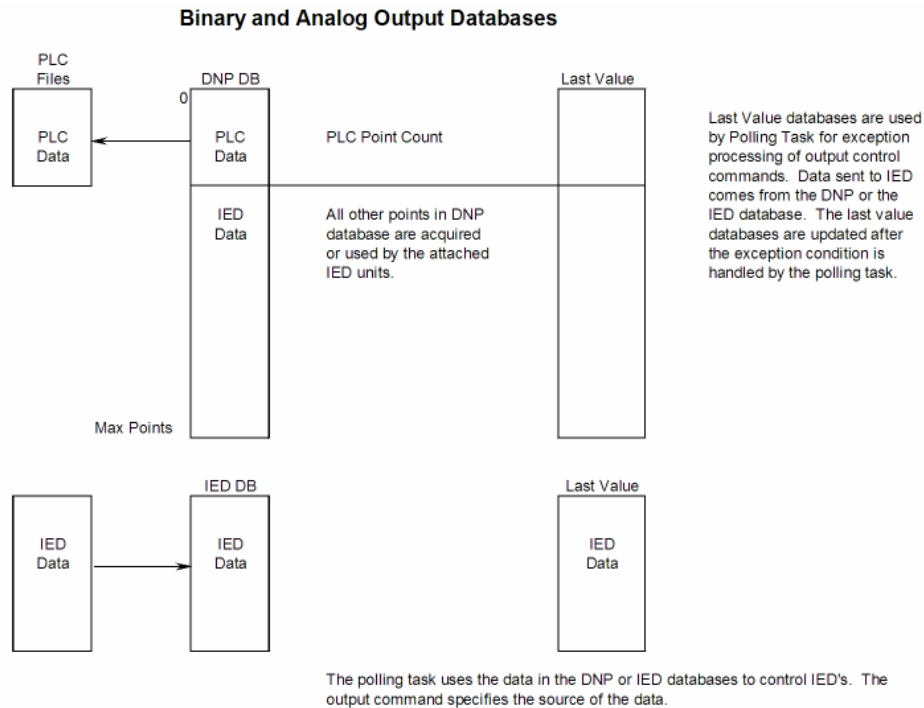

The DNP database consists of data from the DNP master on the slave port. This data is passed to the PLC and to the IED units through the command list. The IED database contains control data generated in the PLC. This is the only data path for PLC control of IED units on the DNP master port. A command must be set up to handle the transfer of data from the IED database to the IED unit. The last value databases are used for exception processing of control commands. Commands can be configured to only generate a message if there is a change in the database. The current values are compared against the last value database to recognize the changes. When a change is recognized, the DNP master port executes a command to the specific IED unit containing the new data.

Side Connect Interface

Data is directly transferred between the module and the PLC data files over the side-connect interface. Code within the module automatically handles the transfer of the data using the module's configuration. Up to 1000 words of data can be transferred on each read or write operation. Because the interface permits direct memory access, each data transaction is almost instantaneous. This interface requires none of the ladder logic or BTR/BTW operations required by the block transfer mode. Each data type used by the module must have a corresponding PLC data file in order for the data transfer to occur.

The following illustration shows the relationship between the PLC5 data files and the DNP and IED memory areas in the module. Note that each data type is allocated its own PLC file. This limits the number of data points that can be defined for each data type to the maximum size of a PLC5 data file.

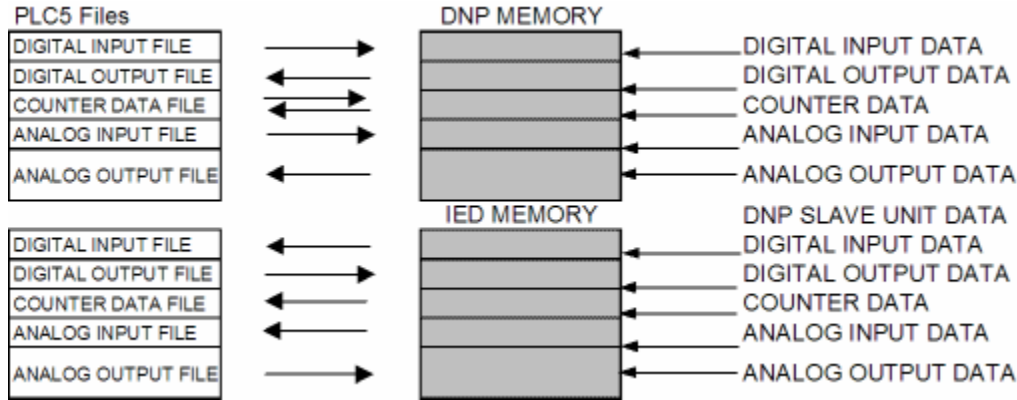

Block Data Transfer Interface

Data can be transferred between the PLC and the module using BTR and BTW operations. Each block transfer operation transfers 64 words of information of which 60 holds data. The other four words in the block contain block header identification codes or are not used. The module defines the blocks to be transferred between the PLC and the module when the system is initialized.

The block transfer numbers are fixed in the program for each data type for your specific application. Block numbers are assigned by the application based on the number of points of each type. The application only allocates the number of blocks required to hold the data point count specified. For example, if 200 digital input points are required for the application, only block 0 is allocated. If 50 counter points are required, blocks 40 and 41 are defined.

The following table shows the block identification numbers used for data transfer.

Data Type	Start Block #	Max Block #	Max # Of Points
Digital Input	0	15	15360
Digital Output	20	35	15360
Counters	40	55	480
Analog Input	60	75	960
Analog Output	80	95	960
IED Digital Input	1000	1015	15360
IED Digital Output	1020	1035	15360
IED Counters	1040	1055	480
IED Analog Input	1060	1075	960
IED Analog Output	1080	1095	960
Float Input	1100	1107	240
Float Output	1140	1147	240

These blocks are mapped into a predefined memory area in the module. Pointers into the memory area are computed by the application for each data type when the module is initialized. The application will only copy the portion of the block that contains valid data. The following illustration shows the relationship of the module data area and the BTR/BTW data.

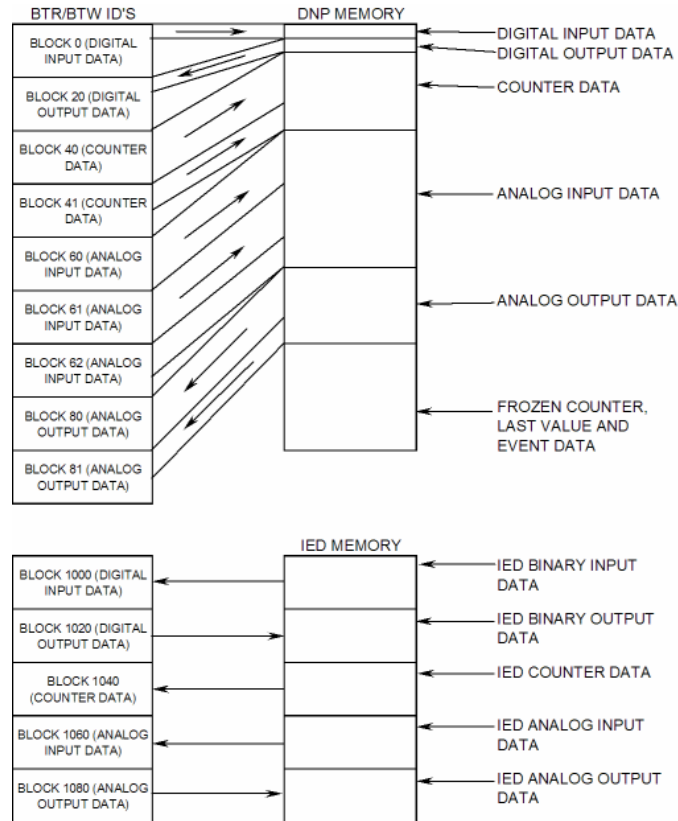

It is important to understand the relationship of the BTR/BTW identifications and the data in the module. Confident data handling in the module is only accomplished if the user defines a consistent set of parameters in the module configuration, handles the BTR/BTW operations for the blocks in the module in the PLC ladder logic and understands the requirements of the DNP master unit. Review the BTR/BTW section of this documentation for further understanding of this process and the ladder logic section on how to implement the operation.

The file data type uses a set of block identification numbers between 100 and 120. The number selected is user defined in the file configuration data table with each file assigned a unique block identification number. The structure of the BTR block is also different from that of the other data types.

The 64-word block has the following structure:

Offset	Variable	Description
0	BTR ID	Block identification code for the DNP user file to consider.
1	BTW ID	Block identification code for the data request from the PLC. This parameter has nothing to do with the user file record update.
2 to 61	Data	This is the data to be written to the file.
62 to 63	Spare	This value is not used.

The record number field is inserted before the data in the block. All records in a file use the same BTR block identification code. Therefore, the record number field is added to define where the data should be placed in the PLC. The ladder logic must process this field and place the data in the appropriate data table.

DNP Digital Input Data

This data type stores the binary value of 1 or 0. The size of this data area is determined from the configuration parameter Number of Binary Input Points. The data area is partitioned into two separate areas. The first is the DNP binary input data acquired from the PLC, and the second is the binary input data from IED units on the DNP master port. The configuration parameter, Number of Binary Input Points for PLC, determines the size of the PLC's data area. The remaining portion is defined as the IED binary input data area.

PLC data are transferred to the module from the PLC using the COP command in the ladder logic. Therefore, these data are read-only for the module and the DNP master unit communicating with the module. When the module receives a new block of this data from the PLC, it compares the new values to those currently in the database. If there is a change in any of the data, the module generates an event message for the points that change.

Data from IED units can also be placed in the DNP binary input data area. Commands in the command list must specify the DNP database address (point number) where the data will be placed.

The remote DNP master unit can read the current status data and the event data from the module. Event messages generated by the module can be retrieved using a poll for Class 2 data, as all digital input events are considered a Class 2 data type. If unsolicited message generation is enabled in the application, the module automatically sends the events to the DNP master unit when the maximum event count for Class 2 data is reached, or when the timeout for unsolicited messages is exceeded. The following shows a data flow diagram for the digital input data:

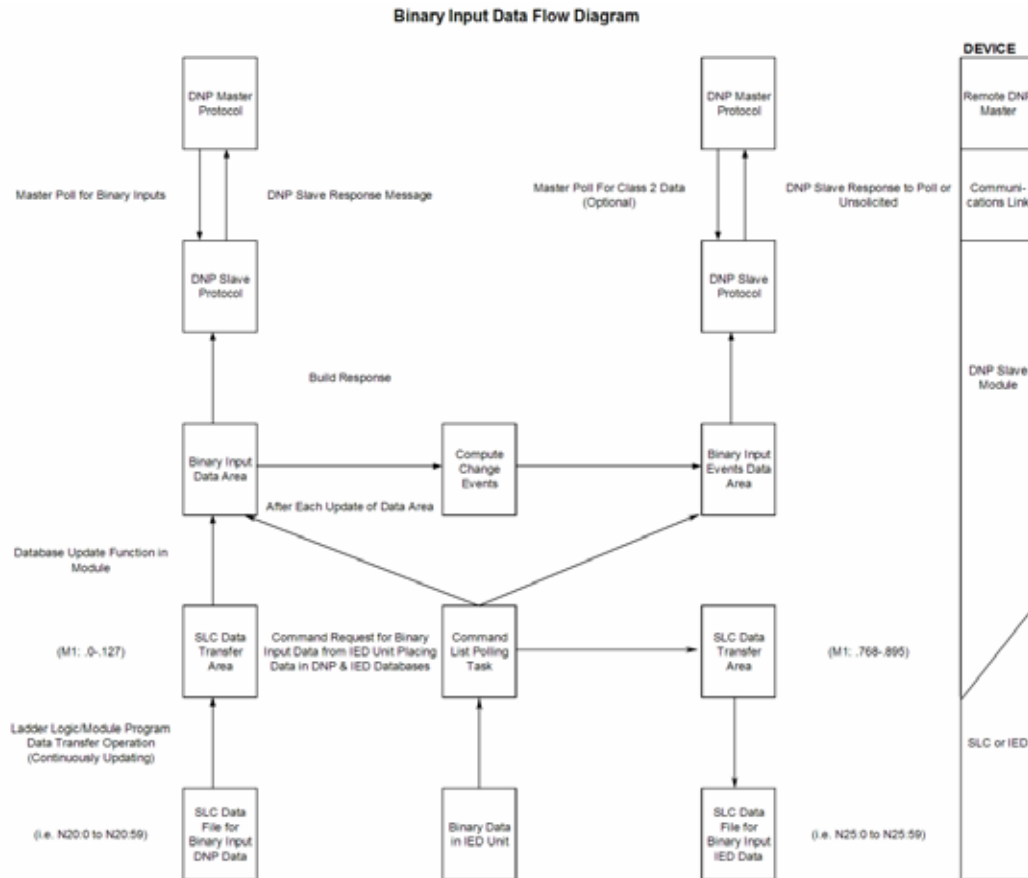

All data associated with the digital inputs is transferred from the PLC to the module using the BTW instruction and blocks 0 to 15. This provides for a maximum number of 15360 points.

DNP Digital Output Data

This data type stores digital control and command state data received from the DNP master unit with a value of 1 or 0. The size of this data area is determined from the configuration parameter Number of Binary Output Points. The area is partitioned into two separate areas. The first area is the DNP binary output data for the PLC, and the second is the DNP binary output data for the IED units. The configuration parameter, Number of Binary Output Points for PLC, determines the size of the PLC's data area. The remaining portion is defined as the IED binary output data area. IED units can use any portion of the DNP binary output data area. The command list instructions are not limited to the IED data area.

PLC data are transferred from the module to the PLC using the COP command from the BTR instruction. Therefore, these data are read-only for the PLC, as the PLC cannot directly alter these values in the module. It is the responsibility of the DNP master unit to maintain this data. For example, if the DNP master sets a digital point to the ON state, it remains ON until the master resets the point. The following shows a data flow diagram for the digital output data:

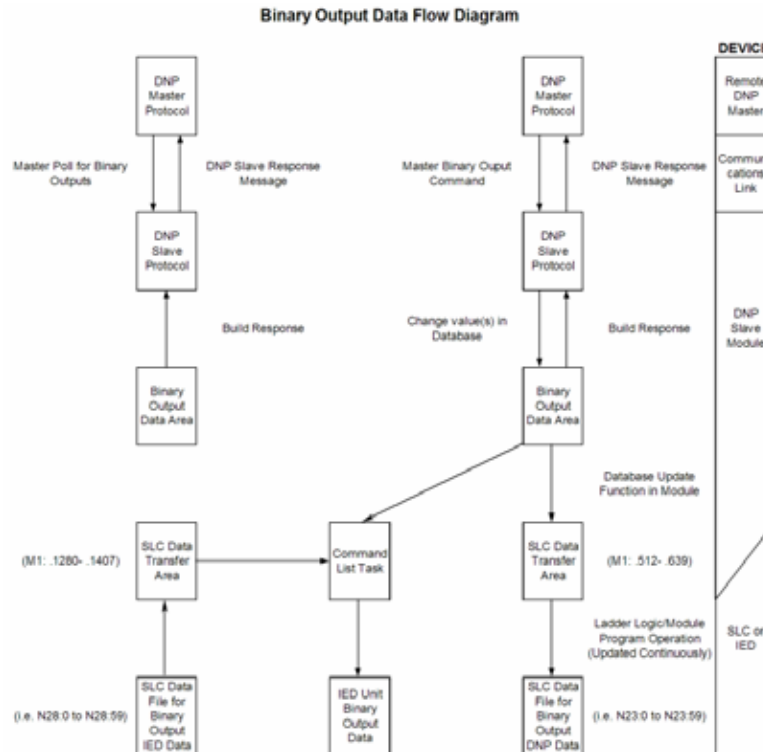

All data associated with the digital outputs is transferred from the module to the PLC using the BTR instruction and blocks 20 to 35. This provides for a maximum number of 15360 points.

Trip/Close

The MVI71-DNP module supports Trip/Close functionality for Binary Output points.

This allows Trip/Close commands to be sent to the MVI71-DNP module, for dual point control. Each DNP Trip/Close command will occupy 2 bits within the module memory.

This does overlap the regular pulse on/off and latch on/off Binary Output database, therefore special consideration must be used to make sure that points are not used twice.

The following table describes the address mapping for the module using Latch and Pulse commands, and Trip/Close functionality.

DNP BO Database Point	BO Latch/Pulse Point	BO Trip/Close Point
0	BO 0	Close BO 0
1	BO 1	Trip BO 0
2	BO 2	Close BO 1
3	BO 3	Trip BO 1
4	BO 4	Close BO 2
5	BO 5	Trip BO 2
100	BO 100	Close BO 50
101	BO 101	Trip BO 50
1000	BO 1000	Close BO 500
1001	BO 1001	Trip BO 500
2046	BO 2046	Close BO 1023
2047	BO 2047	Trip BO 1023

As you can see from the above chart, trip/close requires 2 points within the module's DNP database. A trip is represented by the value of 2#10 for those 2 points, and a close is represented by the value of 2#01 for those same 2 points.

DNP Counter Data

This data type stores accumulated count data. These data are stored in the module in a double word value and have a data range of 0 to 4,294,967,296. The size of this data area is determined from the configuration parameter Number of Counter Points. The data area is partitioned into two separate areas. The first is the DNP counter data acquired from the PLC, and the second is the counter data from the IED units. The configuration parameter, Number of Counter Points for PLC, determines the size of the PLC's data area. The remaining portion is defined as the IED counter data area.

The PLC transfers data of this type to the module using COP command. The module maintains two values for each counter point: a current running value and a frozen value. The DNP master must send the freeze command to the module in order to transfer the current running values to the frozen area. Additionally, the DNP master can send a freeze/clear command to the module. This causes the frozen counter area to be updated with the current running values, and then the current running values are reset to zero. **The values will only be zeroed in the module's counter database and not in the PLC.** Data from IED units can also be placed in the DNP counter data area. Commands in the command list must specify the DNP database address (point number) where the data will be placed. Both frozen counter and counter data values obtained from the IED units are placed in the counter data. The frozen counter data is only updated on a request from the remote DNP master. The counter data from the IED units can be read by the remote DNP master unit connected to the DNP slave port.

The following shows a data flow diagram for the counter data:

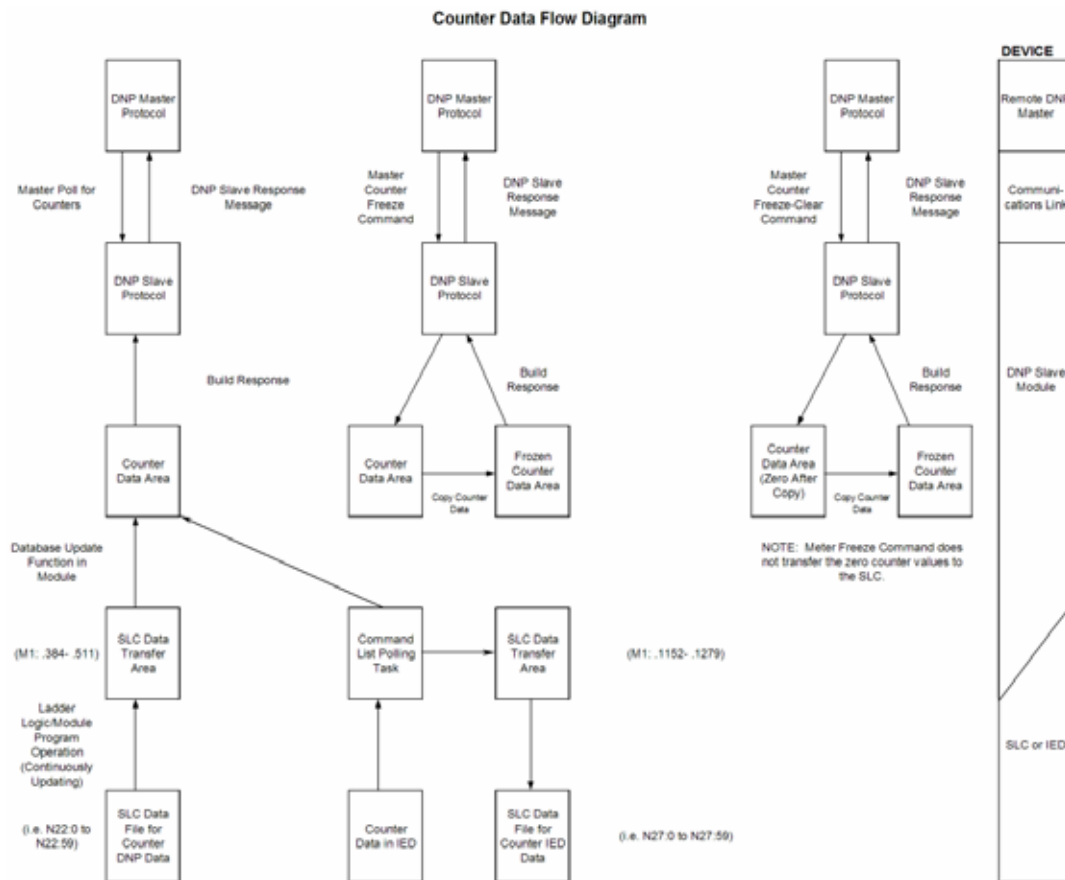

All the current running counter data is transferred from the PLC to the module using the BTW instruction and blocks 40 to 55. This provides for a maximum number of 480 counter values.

DNP Analog Input Data

This data type stores analog data with a data range of 0 to 65535 or –32768 to 32767. The size of this data area is determined from the configuration parameter Number of Analog Input Points. The data area is partitioned into two separate areas. The first is the DNP analog input data acquired from the PLC and the second is the analog input data from IED units. The configuration parameter, Number of Analog Input Points for PLC, determines the size of the PLC's data area. The remaining portion is defined as the IED analog input data area.

PLC data are transferred to the module from the PLC using the COP command. Therefore, these data are read-only for the module and the DNP master unit. When the module receives new data from the PLC, it compares the new values to those currently in the database. If there is a change in any of the data, the module generates an event message for the points that change. The dead-band parameter configured for the module determines the variance required to generate an event message.

Data from IED units can also be placed in the DNP analog input data area. Commands in the command list must specify the DNP database address (point number) where the data will be placed.

The DNP master unit can read the current value data and the event data from the module. Event messages generated by the module can be retrieved using a poll for Class 3 data, as all analog input events are considered a Class 3 data type. If unsolicited message generation is enabled in the application, the events are automatically sent by the module to the DNP master unit when the maximum event count for Class 3 data is reached or when the timeout for unsolicited messages is exceeded. The following shows a data flow diagram for the analog input data:

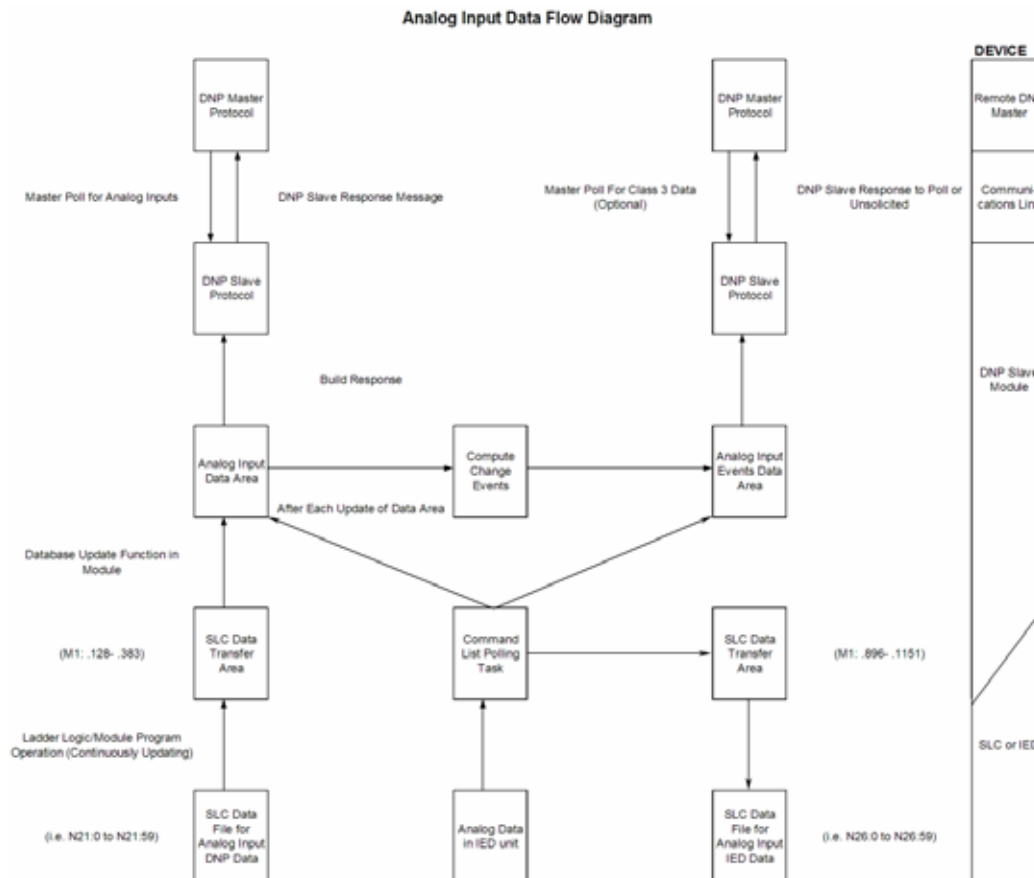

All data associated with the analog inputs is transferred from the PLC to the module in BTW instruction and blocks 60 to 75. This provides for a maximum number of 960 points.

DNP Analog Output Data

This data type stores analog values sent from the DNP master unit to the module and PLC with a data range of 0 to 65535 or -32768 to 32767. The size of this data area is determined from the configuration parameter Number of Analog Output Points. The area is partitioned into two separate areas. The first area is the DNP analog output data for the PLC and the second is the DNP analog output data for the IED units. The configuration parameter, Number of Analog Output Points for PLC, determines the size of the PLC's data area. The remaining portion is defined as the IED analog output data area. IED units can use any portion of the DNP analog output data area. The command list instructions are not limited to the IED data area.

PLC data are transferred from the module to the PLC using the COP command operation. Therefore, these data are read-only for the PLC, as the PLC cannot directly alter these values in the module. It is the responsibility of the DNP master unit to maintain this data. For example, if the DNP master sends a value of 3405 to the module for a specific point, the value will be stored in the module until changed by the master. The following shows a data flow diagram for the analog output data:

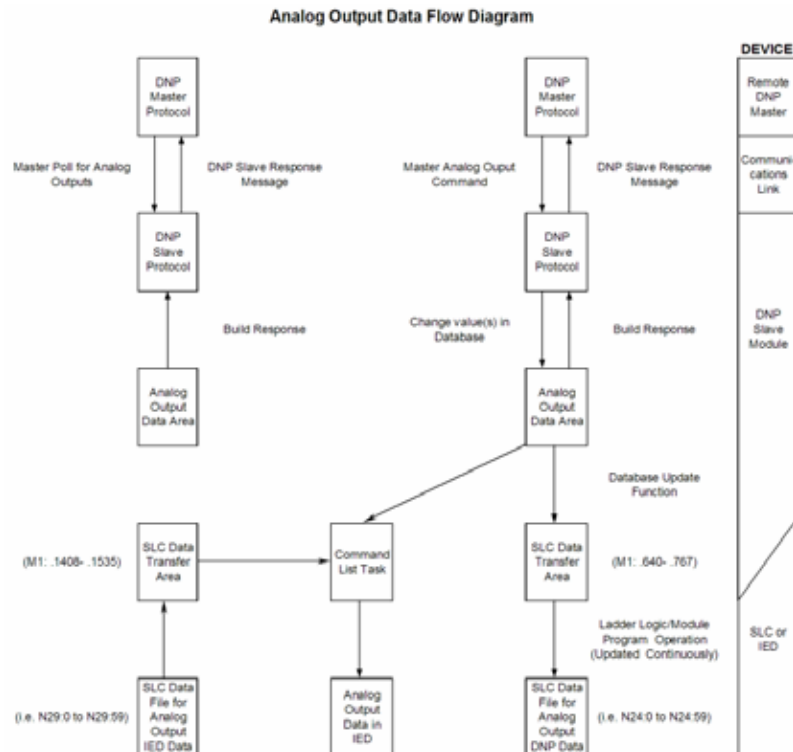

All data associated with the analog outputs is transferred from the module to the PLC using BTR instruction and blocks 80 to 95. This provides for a maximum number of 960 points.

IED Binary Input Data

This data area stores binary input data retrieved from IED units attached to the DNP master port. The size of the data area is determined by the configuration parameter Number of Binary Input Points for IED. The command list polls IED units for their binary input data and to place the data in the database. The PLC program uses this input data for monitoring and control in the ladder logic program. The module transfers these data using BTR instruction and blocks 1000 to 1015. This provides for 15360 binary input points.

IED Binary Output Data

This data area controls IED units attached to the DNP master port. The size of the data area is determined by the configuration parameter Number of Binary Output Points for IED. The command list sends the control values in this database to the IED units. The PLC ladder logic program is responsible for setting the values in this database. This provides direct control of IED units by the PLC program. The module transfers these data using BTW instruction and blocks 1020 to 1035. This provides for 15360 binary output points.

IED Counter Data

This data area stores counter and frozen counter data retrieved from IED units attached to the DNP master port. The size of the data area is determined by the configuration parameter Number of Counter Points for IED. The command list polls the IED units for their counter or frozen counter data. The PLC program uses this data for monitoring or control in the ladder logic program. The module transfers these data to the PLC using BTR instruction and blocks 1040 to 1055. This provides for 480 counter points.

IED Analog Input Data

This data area stores the analog input data retrieved from IED units attached to the DNP master port. The size of the data area is determined by the configuration parameter Number of Analog Input Points for IED. The command list polls the IED units for their analog input data. The PLC program uses this input data for monitoring and control in the ladder logic program. The module transfers these data using BTR instruction and blocks 1060 to 1075. This provides for 960 analog input points.

IED Analog Output Data

This data area controls IED units attached to the DNP master port. The size of the data area is determined by the configuration parameter Number of Analog Output Points for IED. The command list sends the control values in this database to the IED units. The PLC ladder logic program is responsible for setting the values in this database. This provides direct control of IED units by the PLC program. These data are transferred to the module from the PLC using the BTW instruction and blocks 1080 to 1095. This provides for 960 analog output points.

5.4 Cable Connections

The application ports on the MVI71-DNP module support RS-232, RS-422, and RS-485 interfaces. Please look at the module to ensure that the jumpers are set correctly to correspond with the type of interface you are using.

Note: When using RS-232 with radio modem applications, some radios or modems require hardware handshaking (control and monitoring of modem signal lines). Enable this in the configuration of the module by setting the UseCTS parameter to 1.

5.4.1 RS-232 Configuration/Debug Port

This port is physically an RJ45 connection. An RJ45 to DB-9 adapter cable is included with the module. This port permits a PC based terminal emulation program to view configuration and status data in the module and to control the module. The cable for communications on this port is shown in the following diagram:

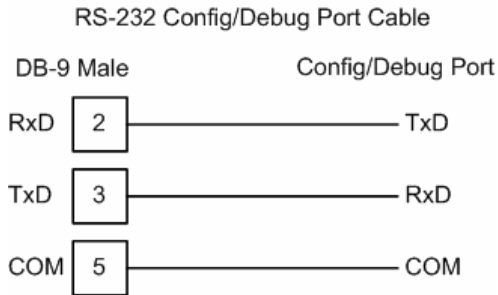

Disabling the RSLinx Driver for the Com Port on the PC

The communication port driver in RSLinx can occasionally prevent other applications from using the PC's COM port. If you are not able to connect to the module's configuration/debug port using HyperTerminal or a similar terminal emulator, follow these steps to disable the RSLinx Driver.

- 1 Open RSLinx and go to Communications>RSWho

- 2 Make sure that you are not actively browsing using the driver that you wish to stop. The following shows an actively browsed network:

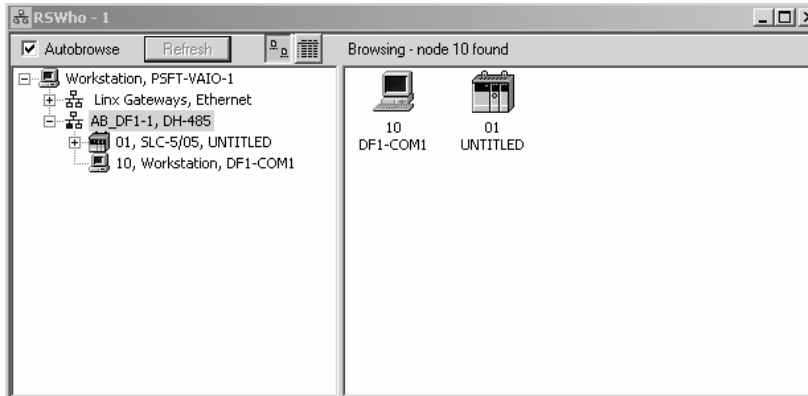

- 3 Notice how the DF1 driver is opened, and the driver is looking for a processor on node 1. If the network is being browsed, then you will not be able to stop this driver. To stop the driver your RSWHo screen should look like this:

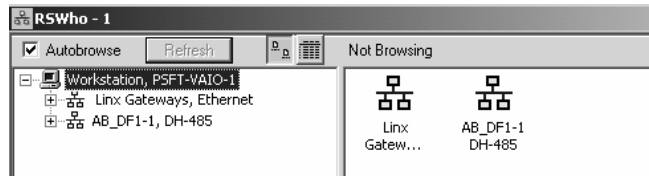

Branches are displayed or hidden by clicking on the  or the  icons.



- 4 When you have verified that the driver is not being browsed, go to **Communications>Configure Drivers**

You may see something like this:

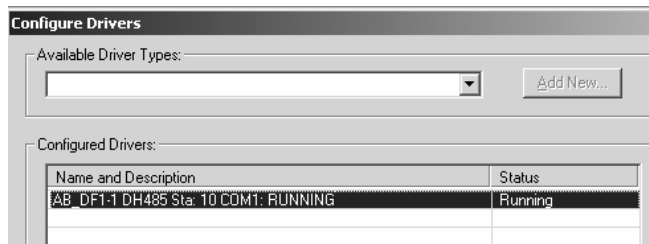

If you see the status as running, you will not be able to use this com port for anything other than communication to the processor. To stop the driver press the "Stop" on the side of the window:



- 5 After you have stopped the driver you will see the following:

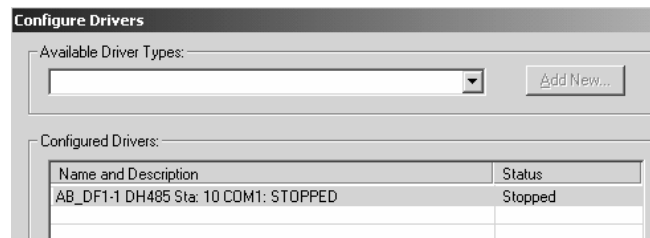

- 6 Upon seeing this, you may now use that com port to connect to the debug port of the module.

Note: You may need to shut down and restart your PC before it will allow you to stop the driver (usually only on Windows NT machines). If you have followed all of the above steps, and it will not stop the driver, then make sure you do not have RSLogix open. If RSLogix is not open, and you still cannot stop the driver, then reboot your PC.

5.4.2 RS-232

When the RS-232 interface is selected, the use of hardware handshaking (control and monitoring of modem signal lines) is user definable. If no hardware handshaking will be used, the cable to connect to the port is as shown below:

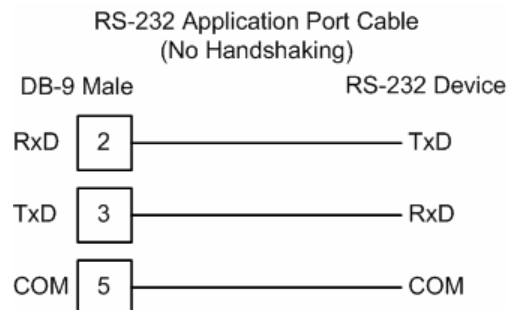

RS-232: Modem Connection

This type of connection is required between the module and a modem or other communication device.

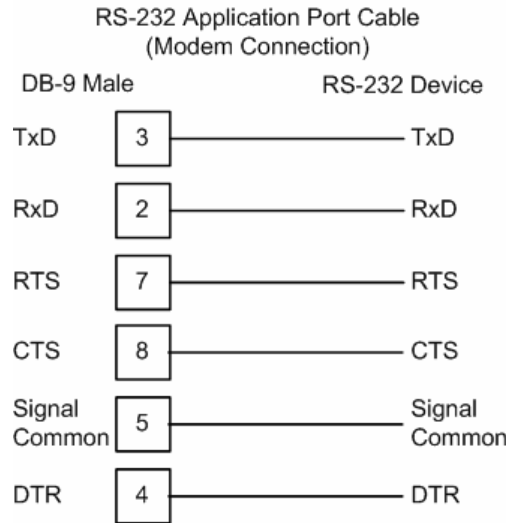

The "Use CTS Line" parameter for the port configuration should be set to 'Y' for most modem applications.

RS-232: Null Modem Connection (Hardware Handshaking)

This type of connection is used when the device connected to the module requires hardware handshaking (control and monitoring of modem signal lines).

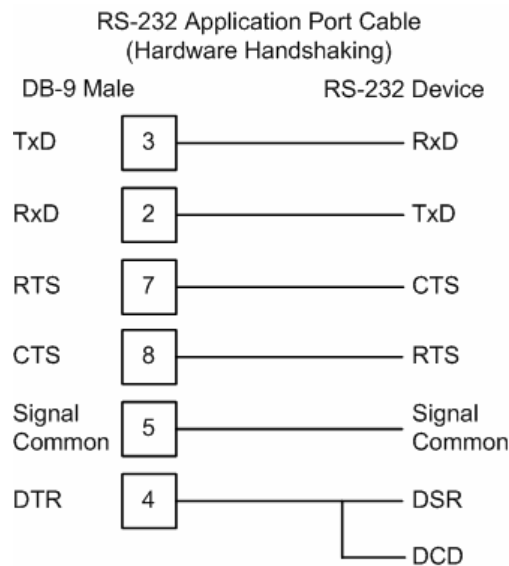

RS-232: Null Modem Connection (No Hardware Handshaking)

This type of connection can be used to connect the module to a computer or field device communication port.

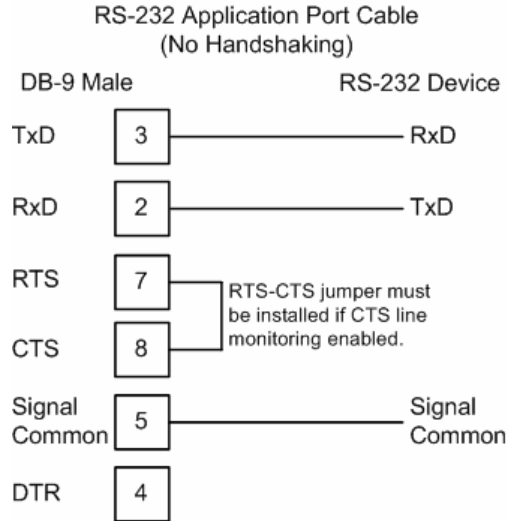

Note: If the port is configured with the "Use CTS Line" set to 'Y', then a jumper is required between the RTS and the CTS line on the module connection.

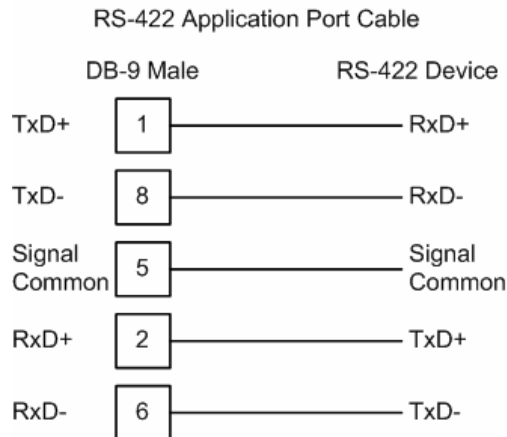
5.4.3 RS-422

5.4.4 RS-485

The RS-485 interface requires a single two or three wire cable. The Common connection is optional and dependent on the RS-485 network. The cable required for this interface is shown below:

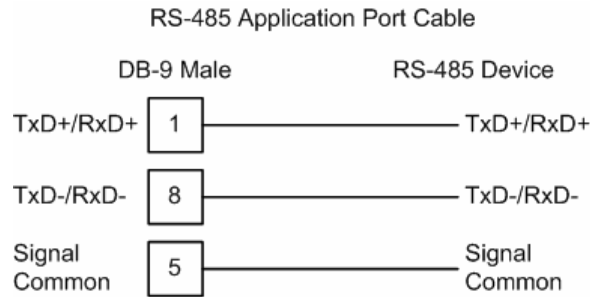

RS-485 and RS-422 Tip

If communication in the RS-422/RS-485 mode does not work at first, despite all attempts, try switching termination polarities. Some manufacturers interpret +/- and A/B polarities differently.

5.4.5 DB9 to RJ45 Adaptor (Cable 14)

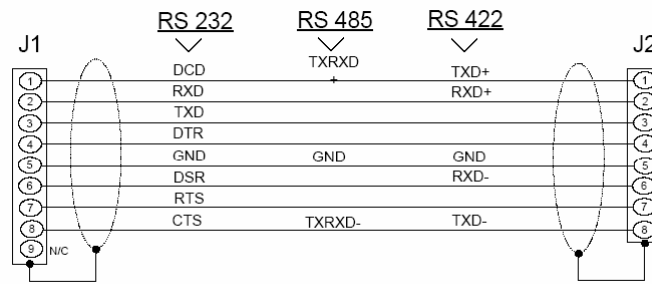
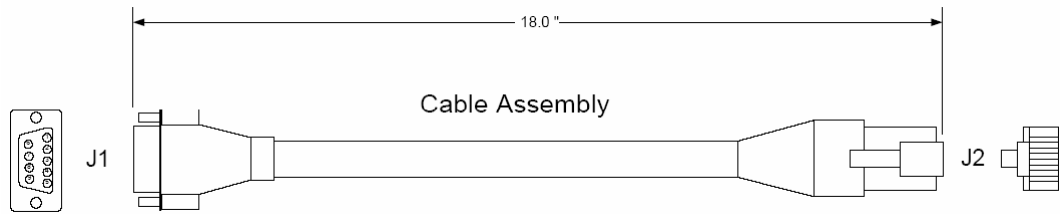

Wiring Diagram

5.5 Collision Avoidance (DNP modules only)

The RTS line is controlled by the RTS on and off parameters set for the port. If the CTS line is used (usually only required for half-duplex modems and not defined for use in the DNPS specification), the RTS and CTS lines must either be connected together or connected to the modem. The following illustration shows the cable required when connecting the port to a modem.

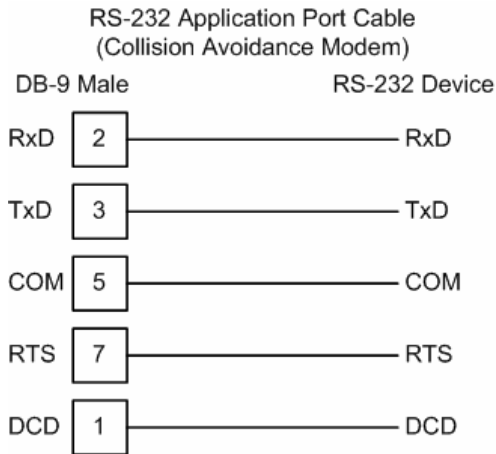

If collision avoidance is used in a point-to-point connection on the RS-232 interface, the following cable should be used.

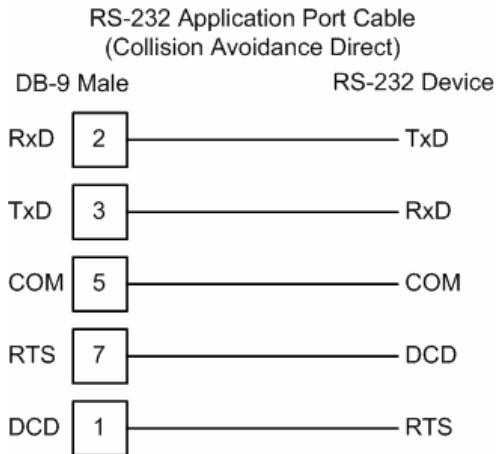

5.6 Block Assignments

5.6.1 PLC Program Block Assignments vs. File:Offset

Binary Inputs (960 points/block)

Block #	PLC File #	Start	End	Points
0	N			1 to 960
1	N			961 to 1920
2	N			1921 to 2880
3	N			2881 to 3840
4	N			3841 to 4800
5	N			4801 to 5760
6	N			5761 to 6720
7	N			6721 to 7680
8	N			7681 to 8640
9	N			8641 to 9600
10	N			9601 to 10560
11	N			10561 to 11520
12	N			11521 to 12480
13	N			12481 to 13440
14	N			13441 to 14400
15	N			14401 to 15360

Binary Outputs (960 points/block)

Block #	PLC File #	Start	End	Points
20	N			1 to 960
21	N			961 to 1920
22	N			1921 to 2880
23	N			2881 to 3840
24	N			3841 to 4800
25	N			4801 to 5760
26	N			5761 to 6720
27	N			6721 to 7680
28	N			7681 to 8640
29	N			8641 to 9600
30	N			9601 to 10560
31	N			10561 to 11520
32	N			11521 to 12480
33	N			12481 to 13440
34	N			13441 to 14400
35	N			14401 to 15360

Counters (30 points/block)

Block #	PLC File #	Start	End	Points
40	N			1 - 30
41	N			31 - 60
42	N			61 - 90
43	N			91 - 120
44	N			121 - 150
45	N			151 - 180
46	N			181 - 210
47	N			211 - 240
48	N			241 - 270
49	N			271 - 300
50	N			301 - 330
51	N			331 - 360
52	N			361 - 390
53	N			391 - 420
54	N			421 - 450
55	N			451 - 480

Analog Inputs (60 points/block)

Block #	PLC File #	Start	End	Points
60	N			1 - 60
61	N			61 - 120
62	N			121 - 180
63	N			181 - 240
64	N			241 - 300
65	N			301 - 360
66	N			361 - 420
67	N			421 - 480
68	N			481 - 540
69	N			541 - 600
70	N			601 - 660
71	N			661 - 720
72	N			721 - 780
73	N			781 - 840
74	N			841 - 900
75	N			901 - 960

Analog Outputs (60 points/block)

Block #	PLC File #	Start	End	Points
80	N			1 to 60
81	N			61 to 120
82	N			121 to 180
83	N			181 to 240
84	N			241 to 300
85	N			301 to 360
86	N			361 to 420
87	N			421 to 480
88	N			481 to 540
89	N			541 to 600
90	N			601 to 660
91	N			661 to 720
92	N			721 to 780
93	N			781 to 840
94	N			841 to 900
95	N			901 to 960

Fill in this form for the application being developed. The data areas in the PLC for the different data types (defined by the start and end values for a PLC file) should not overlap. If they do, unpredictable results may occur. For example, do not define the same address range of N10:0 to 59 for both digital inputs and outputs.

The difference between the end and start addresses in the PLC files should not exceed 60 words. For example 0 to 60 is invalid. Whereas, 0 to 59 is valid.

Note that the number of points represented in each block is denoted. Also shown is the point range for the points defined for the block if the maximum 60 words are defined.

5.7 DNP Configuration Forms

This section contains a configuration form to be used when designing an application.

5.7.1 DNP User File Configuration

File #: Name:

Rec #	PLC File #	Start	End
0			
1			
2			
3			
4			
5			
6			
7			
8			
9			
10			
11			
12			
13			
14			
15			
16			
17			
18			
19			
20			
21			
22			
23			
24			
25			
26			
27			
28			
29			
30			
31			
32			

Rec #	PLC File #	Start	End
33			
34			
35			
36			
37			
38			
39			
40			
41			
42			
43			
44			
45			
46			
47			
48			
49			
50			
51			
52			
53			
54			
55			
56			
57			
58			
59			
60			
61			
62			
63			
64			
65			
66			
67			
68			
69			
70			
71			
72			
73			

Rec #	PLC File #	Start	End
74			
75			
76			
77			
78			
79			
80			
81			
82			
83			
84			
85			
86			
87			
88			
89			
90			
91			
92			
93			
94			
95			
96			
97			
98			
99			

CFG+#	FILE #	FILE SIZE	Description
0	N	150	Configuration information source, modem setup string and phone number and command information.
1	N	60	File setup information source
2	N	120	Error/Status and Error List data destination
3	N	(960 max)	Digital input data source
4	N	(960 max)	Digital output data source
5	N	(960 max)	Counter data source and destination
6	N	(960 max)	Analog input data source
7	N	(960 max)	Analog output data destination
8	N	(960 max)	IED digital input data destination
9	N	(960 max)	IED digital output data source
10	N	(960 max)	IED counter data destination

CFG+#	FILE #	FILE SIZE	Description
11	N	(960 max)	IED analog input data destination
12	N	(960 max)	IED analog output data source
13	N	(960 max)	DNP slave setup data for DNP master on Port 2. Each file contains 96 slaves with a total maximum of 252 slaves.
14	N	(960 max)	
15	N	(600 max)	
16	N	(960 max)	DNP command list data for DNP master on Port 2. Only set up the files required to hold the commands. Each file contains 96 commands with a total maximum of 1200 commands.
17	N	(960 max)	
18	N	(960 max)	
19	N	(960 max)	
20	N	(960 max)	
21	N	(960 max)	
22	N	(960 max)	
23	N	(960 max)	
24	N	(960 max)	
25	N	(960 max)	
26	N	(960 max)	
27	N	(960 max)	
28	N	(480 max)	

5.8 MVI71-DNP Communication Module Configuration

[Section]/Item	Value	Range	Description
[MODULE]			General module configuration section
Module Name:		0 to 80 characters	This parameter assigns a name to the module that can be viewed using the configuration/debug port. Use this parameter to identify the module and the configuration file.

[Section]/Item	Value	Range	Description
[DNP Slave]			DNP Slave configuration information
Internal Slave ID:		0 to 65534	This is the DNP address for the module. All messages with this address from the master will be processed by the module.
Baud Rate:		Baud rate value	Primary DNP Port Baud Rate: 300, 600, 1200, 2400, 4800, 9600, 19200, 384 (38400), 576 (57600), 115 (115200)
RTS On:		0 to 65535 milliseconds	This value represents the number of 1 ms increments to be inserted between asserting the RTS modem line and the actual transmission of the data.
RTS Off:		0 to 65535 milliseconds	This value represents the number of 1 ms increments to be inserted after the last character of data is transmitted before the RTS modem line is dropped.

[Section]/Item	Value	Range	Description
Min Response Delay:		0 to 65535 milliseconds	Minimum time between receiving a request and transmitting a response. Allows master time to disable transmitter on an RS-485 network.
Modem:		Yes or No	This parameter defines if a dial-up modem is used on the secondary DNP slave port. A modem cannot be used if the port is configured as a master.
Connect Timeout:		0 to 65535	Defines the number of milliseconds to wait for the CD signal to be set high. The CD signal indicates a connection is made using a dial-up modem.
First Character Delay:		0 to 65535	Defines the number of milliseconds to wait before sending the first message after the connection is first made. This delay only applies to the first packet sent to the modem.
Redial Delay Time:		0 to 32000	Defines the minimum number of milliseconds to wait before a redial attempt is made by the slave.
Redial Random Delay:		0 to 32000	Defines a random millisecond time range to be added to the redial delay time before the modem is accessed.
Idle Timeout:		0 to 65535	Defines the number of milliseconds the modem is inactive before it will disconnect.
Phone Number:		ASCII String Data	This field contain a null-terminated, ASCII character string used by the dial-up modem. The string must contain all characters required by the modem. An example string is ATDT1800222333. Maximum length is 34 bytes including the terminating 0.
Collision Avoidance:		Yes or No	This parameter defines if collision avoidance will be utilized on the primary DNP slave port.
CD Idle Time:		0 to 32000	Defines the minimum number of milliseconds to wait before transmitting a message after the CD signal is recognized as low.
CD Random Time:		0 to 32000	Defines the range of random time to be added to the CD Idle Time before a message will be transmitted from the slave.
CD Time Before Receive:		0 to 65535	Defines the number of milliseconds to wait before receiving characters after the CD signal is recognized as high.
BI Class:		0 to 3	This parameter specifies the default class to be utilized for all the binary input points in the DNP database that are not defined in the override list section.
AI Class:		0 to 3	This parameter specifies the default class to be utilized for all the analog input points in the DNP database that are not defined in the override list section.

[Section]/Item	Value	Range	Description
Float Class:		0 to 3	This parameter specifies the default class to be utilized for all the floating-point input points in the DNP database that are not defined in the override list section.
AI Deadband:		0 to 32767	This parameter specifies the default deadband value assigned to all points not defined in the override list for the analog input point type in the DNP database.
Float Deadband:		0 to maximum float value	This parameter specifies the default deadband value assigned to all points not defined in the override list for the floating-point input point type in the DNP database.
Select/Operate Arm Time:		1 to 65535 milliseconds	Time period after select command received in which operate command will be performed. After the select command is received, the operate command will only be honored if it arrives within this period of time.
Write Time Interval:		0 to 1440 minutes	Time interval to set the need time IIN bit (0=never), which will cause the master to write the time. Stored in milliseconds in the module memory.
Data Link Confirm Mode:		Coded Value (N=Never, S=Sometimes, A=Always)	IED can request acknowledgement from master station when sending data. The codes are as follows: 0=Never, 1=Sometimes, 2=Always
Data Link Confirm Tout:		1 to 65535 milliseconds	Time period to wait for Master Data Link confirmation of last frame sent. This time is in milliseconds. This parameter is only used if the frame is sent with confirmation requested.
Data Link Max Retry:		0 to 255 retries	Maximum number of retries at the Data Link level to obtain a confirmation. If this value is set to 0, retries are disabled at the data link level of the protocol. This parameter is only used if the frame is sent with confirmation requested.
App Layer Confirm Tout:		1 to 65535 milliseconds	Event data contained in the last response may be sent again if not confirmed within the millisecond time period set. If application layer confirms are used with data link confirms, ensure that the application layer confirm timeout is set long enough.
Unsolicited Response:		Yes or No	Set if the slave unit will send unsolicited response messages. If set to No, the slave will not send unsolicited responses. If set to Yes, the slave will send unsolicited responses.
Class 1 Unsol Resp Min:		1 to 255 events	Minimum number of events in Class 1 required before an unsolicited response will be generated.
Class 2 Unsol Resp Min:		1 to 255 events	Minimum number of events in Class 2 required before an unsolicited response will be generated.

[Section]/Item	Value	Range	Description
Class 3 Unsol Resp Min:		1 to 255 events	Minimum number of events in Class 3 required before an unsolicited response will be generated.
Unsol Resp Delay:		0 to 65535 milliseconds	Maximum number of 1 millisecond intervals to wait after an event occurs before sending an unsolicited response message. If set to 0, only use minimum number of events.
Uresp Master Address:		0 to 65534	DNP destination address where unsolicited response messages are sent.
Uresp Retry Count:		0 to 255 retries	Determines the number of unsolicited message retries sent on primary DNP port before changing to secondary port. If the value is 0, port switching will be disabled.
AI Events with time:		Yes or No	This parameter sets if the analog input events generated by the module will include the date and time of the event. If the parameter is set to No, the default is set to no time data. If the parameter is set to Yes, the default object will include the time of the event.
Time Sync Before Events:		Yes or No	This parameter determines if events are to be generated by the module before the time synchronization from the master unit. If the parameter is set to No, no events will be generated until the module's time has been synchronized. If the parameter is set to Yes, events will always be generated.
Initialize DNP Database:		Y or N	This parameter determines if the module will request data from the processor to initialize the DNP database output data areas. If this option is utilized, ladder logic is required to send the requested block from the processor to the module.
[Section]/Item	Value	Range	Description
[DNP Slave Database]			DNP Slave Database definition
Binary Inputs:		0 to 15360 points	Number of digital input points to configure in the DNP slave device. Each point will be stored as a single bit in the module memory.
PLC Binary Inputs:		0 to 15360 points	Number of digital input points configured above that are to be obtained from the PLC processor. All other binary input points must come from the attached IED units.
Analog Inputs:		0 to 960 points	Number of analog input points to configure in the DNP slave device. Each point will occupy a one word area in the module memory.
PLC Analog Inputs:		0 to 960 points	Number of analog input points configured above that are to be obtained from the PLC processor. All other analog input points must come from the attached IED units.

[Section]/Item	Value	Range	Description
Float Inputs:		0 to 240 points	Number of floating-point input points to configure in the DNP slave device. Each point will occupy a two-word area in the module memory.
PLC Float Inputs:		0 to 240 points	Number of floating-point input points configured above that are to be obtained from the PLC.
Counters:		0 to 480 points	Number of counter points to configure in the DNP slave device. Each point will occupy a two word area in the module memory. This number corresponds to the number of frozen counters. The application maps the counters to the frozen counters directly.
PLC Counters:		0 to 480 points	Number of counter points configured above that are to be obtained from the PLC processor. All other counter points must come from the attached IED units.
Binary Outputs:		0 to 15360 points	Number of digital output points to configure in the DNP slave device. Each point will be stored as a single bit in the module memory.
PLC Binary Outputs:		0 to 15360 points	Number of digital output points configured above that are to be sent to the PLC processor. All other binary output points will be sent to the attached IED units.
Analog Outputs:		0 to 960 points	Number of analog output points to configure in the DNP slave device. Each point will occupy a one word area in the module memory.
PLC Analog Outputs:		0 to 960 points	Number of analog output points configured above that are to be sent to the PLC processor. All other analog output points will be sent to the attached IED units.
Float Outputs:		0 to 240 points	Number of floating-point output points to configure in the DNP slave device. Each point will occupy a two- word area in the module memory.
PLC Float Outputs:		0 to 240 points	Number of floating-point output points configured above that are to be sent to the PLC.

[Section]/Item		Description
[DNP Slave Binary Inputs]		DNP database binary input override values
		# This area is to override the class assignment for binary input database points. Enter list of points between the
		# START and END labels.
		#
		# Point# Class
		START
		END

[Section]/Item		Description	
[DNP Slave Analog Inputs]		DNP database analog input override values	
START			
# This area is to override the class and deadband assignment for analog input database points. Enter list of points			
# between the START and END labels.			
#			
# Point# Class Deadband			
START			
END			
[Section]/Item		Description	
[DNP Slave Float Inputs]		DNP database floating-point input override values	
# This area is to override the class and deadband assignment for float input database points. Enter list of points			
# between the START and END labels.			
#			
# Point# Class Deadband			
START			
END			
[Section]/Item	Value	Range	Description
[Secondary Port]			Definitions for secondary port on module
Type:		M or S or blank	This parameter defines the functionality of the secondary port on the module. M = emulate a DNP master port S = back-up DNP slave port to the primary port. Any other value will disable the port.
Baud Rate:		Baud rate value	Secondary DNP Port Baud Rate: 300, 600, 1200, 2400, 4800, 9600, 19200, 384 (38400), 576 (57600), 115 (115200)
RTS On:		0 to 65535 milliseconds	This value represents the number of 1 ms increments to be inserted between asserting the RTS modem line and the actual transmission of the data.
RTS Off:		0 to 65535 milliseconds	This value represents the number of 1 ms increments to be inserted after the last character of data is transmitted before the RTS modem line is dropped.

[Section]/Item	Value	Range	Description
Min Response Delay:		0 to 65535 milliseconds	Minimum time between receiving a request and transmitting a response. Allows master time to disable transmitter on an RS-485 network.
Collision Avoidance:		Yes or No	This parameter defines if collision avoidance will be utilized on the primary DNP slave port.
CD Idle Time:		0 to 32000	Defines the minimum number of milliseconds to wait before transmitting a message after the CD signal is recognized as low.
CD Random Time:		0 to 32000	Defines the range of random time to be added to the CD Idle Time before a message will be transmitted from the slave.
CD Time Before Receive:		0 to 65535	Defines the number of milliseconds to wait before receiving characters after the CD signal is recognized as high.

[Section]/Item	Value	Range	Description
[DNP Master]			Definitions for DNP Master port if utilized.
Internal ID:		0 to 65534	This is the DNP address for the module. All messages with this address from the master will be processed by the module.
Initialize IED Database:		Yes or No	This parameter determines if the module will request data from the processor to initialize the IED database input data areas. If this option is utilized, ladder logic is required to send the requested block from the processor to the module.
Event Messages to PLC:		Yes or No	This parameter determines if event messages received on the master port will be sent to the processor. If this option is utilized, ladder logic must handle the 9903 blocks generated by the module.

[Section]/Item	Value	Range	Description
[IED Database]			Database definition for DNP master port if utilized
Binary Inputs:		0 to 15360 points	Number of binary input points contained in the IED database to transfer to the PLC processor and obtained from the attached IED units.
Analog Inputs:		0 to 960 points	Number of analog input points contained in the IED database to transfer to the PLC processor and obtained from the attached IED units.
Counters:		0 to 480 points	Number of counter points contained in the IED database to transfer to the PLC processor and obtained from the attached IED units.

[Section]/Item	Value	Range	Description
Binary Outputs:		0 to 15360 points	Number of binary output points contained in the IED database which are transferred from the PLC processor and used by the attached IED units.
Analog Outputs:		0 to 960 points	Number of analog output points contained in the IED database which are transferred from the PLC processor and used by the attached IED units.

[Section]/Item		Description
[DNP Master Slave List]		Definition of the IED units to be interfaced with the DNP master port if utilized
# This section stores information about each slave to be used by the master port. There must be an entry in this table for each node to be used in the command list. Two of the parameters in this list are coded # values: # Conf Mode ==> 0=Never, 1=Sometimes and 2=Always (select 0). # Flags is bit coded as follows: # Bit 0 (decimal 1) ==> Enable the slave # Bit 1 (decimal 2) ==> Use Unsolicited messaging with this slave # Bit 2 (decimal 4) ==> Use delay measurement with this slave # Bit 3 (decimal 8) ==> Auto time synchronization enabled # # Node DL Conf Conf Conf App Rsp # Address Mode Timeout Retry Timeout Flags START END		

[Section]/Item		Description
[DNP Master Commands]		Definition of the commands to be issued to the IED units by the DNP master port.
# This section contains the list of commands to process on the master port. # Node addresses present in the command list must have an entry in the # [DNP Slave List]. Commands with nodes not present in the list will not be # executed. # 1 2 3 4 5 6 7 8 9 10 #Flags/ Node Data Data Cmd Device Point DNP DB IED DB Poll #Enable Address Object Variation Func Address Count Address Address interval START END		

5.9 Error Status Table

The program maintains an error/status table. This table of data is available to the PLC processor automatically through block 100. Ladder logic should be programmed to accept this block of data and place it in the module's controller tag. You can use the error/status data to determine the "health" of the module.

The data in the block is structured as shown in the following table:

Word	Block Offset	Variable Name	Description
0	2	Current DNP Slave Port status	This value represents the current value of the error code for the port. This value will only be valid if the port is configured as a slave. The possible values are described in the application documentation.
1	3	DNP Slave Port last transmitted error code	This value represents the last error code transmitted to the master by this slave port.
2	4	DNP Slave Port total number of message frames received by slave	This value represents the total number of message frames that have matched this slaves address on this port. This count includes message frames which the slave may or may not be able to parse and respond.
3	5	DNP Slave Port total number of response message frames sent from slave	This value represents the number of good (non-error) responses that the slave has sent to the master on this port. The presumption is that if the slave is responding, the message was good. Note: This is a frame count.
4	6	DNP Slave Port total number of message frames seen by slave	This value represents the total number of message frames received by the slave, regardless of the slave address.
5	7	DNP Slave synchronization error count (Physical Layer Error)	This value counts the number of times a sync error occurs. The error occurs when extra bytes are received before the start bytes (0x05 and 0x64) are received.
6	8	DNP Slave overrun error count (Physical Layer Error)	This value counts the number of times the overrun error occurs. This error occurs when the mainline Data Link Layer routine cannot read the data received on the communication port before it is overwritten.
7	9	DNP Slave length error count (Physical Layer Error)	This value counts the number of times an invalid length byte is received. If the length of the message does not match the length value in the message, this error occurs.
8	10	DNP Slave bad CRC error (Data Link Layer Error)	This value counts the number of times a bad CRC value is received in a message.
9	11	DNP Slave user data overflow error (Transport Layer Error)	This value counts the number of times the application layer receives a message fragment buffer which is too small.
10	12	DNP Slave sequence error (Transport Layer Error)	This value counts the number of times the sequence numbers of multi-frame request fragments do not increment correctly.

Word	Block Offset	Variable Name	Description
11	13	DNP Slave address error (Transport Layer Error)	This value counts the number of times the source addresses contained in a multi-frame request fragments do not match.
12	14	DNP Slave Binary Input Event count	This value contains the total number of binary input events which have occurred.
13	15	DNP Slave Binary Input Event count in buffer	This value represents the number of binary input events which are waiting to be sent to the master.
14	16	DNP Slave Analog Input Event count	This value contains the total number of analog input events which have occurred.
15	17	DNP Slave Analog Input Event count in buffer	This value represents the number of analog input events which are waiting to be sent to the master.
16	18	DNP Slave bad function code error (Application Layer Error)	This value counts the number of times a bad function code for a selected object/variation is received by the slave device.
17	19	DNP Slave object unknown error (Application Layer Error)	This value counts the number of times a request for an unsupported object is received by the slave device.
18	20	DNP Slave out of range error (Application Layer Error)	This value counts the number of times a parameter in the qualifier, range or data field is not valid or out of range.
19	21	DNP Slave message overflow error (Application Layer Error)	This value counts the number of times an application response message from the slave is too long to transmit.
20	22	DNP Slave multi-frame message from DNP Master error (Application Layer Error)	This value counts the number of times the slave receives a multi-frame message from the master. The application does not support multi-frame master messages.
21	23	Total blocks transferred	Total BTR/BTW or side-connect interface transfers attempted by the module.
22	24	Successful blocks transferred	This value represents the total number of transfer operations between the PLC processor and module that are successful.
23	25	Total errors in block transfer	Total number of transfers that resulted in an error condition.
24	26	Total BTR or write errors	Total number of BTR or write transfers that resulted in an error.
25	27	Total BTW or read errors	Total number of BTW or read transfers that resulted in an error.
26	28	Block number error	Number of BTW requests that resulted in an incorrect BTW identification code.
27	29	Continuous block error counter	Count of sequential data transfer errors. When this value exceeds that specified for the data transfer operation, the error flag below will be set.
28	30	Reserved	Not used
29	31	Configuration Type	This is a coded field that defines the configuration of the module. The codes are as follows: 0=Single Slave Configuration, 1=Dual Slave Configuration, 2=Slave/Master Configuration

Word	Block Offset	Variable Name	Description
30 to 31	32 to 33	Product Name (ASCII)	These two words contain the product name of the module in ASCII format.
32 to 33	34 to 35	Revision (ASCII)	These two words contain the product revision level of the firmware in ASCII format.
34 to 35	36 to 37	Operating System Revision (ASCII)	These two words contain the module's internal operating system revision level in ASCII format.
36 to 37	38 to 39	Production Run Number (ASCII)	These two words contain the production 'batch' number for the particular chip in the module in ASCII format.
38	40	DNP Master Port Slave Count	This is the total number of slaves configured for the DNP Master port. This may not represent the number of active slaves as it includes slaves that are not enabled.
39	41	DNP Master Port Command Count	This is the total number of commands configured for the DNP Master port. This may not represent the number of active commands as it includes commands that are disabled.
40	42	DNP Master Port Device Memory Block Count	This value represents the number of memory allocation blocks for slave devices. This number should be one greater than the number of slave devices. The extra device is held for the broadcast device.
41	43	DNP Master Port Frame Block Count	This value represents the number of physical layer frame memory allocation blocks used by the program.
42	44	DNP Master Port Data Link Receive Block Count	This value represents the number of receive data link layer memory blocks allocated.
43	45	DNP Master Port Data Link Transmit Block Count	This value represents the number of transmit data link layer memory blocks allocated.
44	46	DNP Master Port Application Layer Receive Block Count	This value represents the number of application layer receive memory blocks allocated.
45	47	DNP Master Port Application Layer Transmit Block Count	This value represents the number of application layer transmit memory blocks allocated.
46	48	DNP Master Port Device Memory Allocation Error Count	This value represents the number of memory allocation errors for device blocks.
47	49	DNP Master Port Physical Layer Memory Allocation Error Count	This value represents the number of memory allocation errors for physical layer frame blocks.
48	50	DNP Master Port Data Link Layer Receive Memory Allocation Error Count	This value represents the number of memory allocation errors for data link layer receive blocks.
49	51	DNP Master Port Data Link Layer Transmit Memory Allocation Error Count	This value represents the number of memory allocation errors for data link layer transmit blocks.
50	52	DNP Master Port Application Layer Receive Memory Allocation Error Count	This value represents the number of memory allocation errors for application layer receive blocks.

Word	Block Offset	Variable Name	Description
51	53	DNP Master Port Application Layer Transmit Memory Allocation Error Count	This value represents the number of memory allocation errors for application layer transmit blocks.
52	54	DNP Master Synchronization Error Count (Physical Layer Error)	This value counts the number of times a sync error occurs. The error occurs when extra bytes are received before the start bytes (0x05 and 0x64) are received.
53	55	DNP Master Length Error Count (Physical Layer Error)	This value counts the number of times an invalid length byte is received. If the length of the message does not match the length value in the message, this error occurs.
54	56	DNP Master Bad CRC Error Count (Physical Layer Error)	This value counts the number of times a bad CRC value is received in a message.
55	57	Scan Counter LSB	Program scan counter
56	58	Scan Counter MSB	
57	59	Free Memory LSB	Free memory in module
58	60	Free Memory MSB	
59	61	DNP Slave Port Transmit State	Value of the DNP Slave state machine for transmit.
60	62	DNP Float Event Count	Total number of events generated for analog floating-point input data points.
61	63	DNP Double Event Count	Total number of events generated for analog double, floating-point input data points.
62	64	Event Message Queue Count	Number of event messages waiting to send to processor.
63	65	Event Message Queue Overflow	Flag to indicate if the event message queue has overflowed. If more than 200 event messages are received on the master port and they are not sent to the processor, this flag will be set (1). The flag will clear after the messages are sent to the processor.
64 to 77	66 to 79	Reserved	Future Use
78	80	Error_List[0]	First value in error list
79	81	Error_List[1]	Second value in error list
-	-	-	-
137	139	Error_List[59]	Last value in error list

5.10 Module Error Codes

If the module's program encounters an error during execution, it will log the error to the error list. This list is transferred to the PLC processor using block identification code 100 (see section above) in at offsets 62 to 119. This data is also available for viewing on the debug monitor port. The following tables list the error codes generated by the program with their associated description. Use the errors to help define where problems exist in the system.

5.10.1 Slave Port Communication Errors

Error Code	Name	Description
0	OK	The module is operating correctly and there are no errors.
10	DNP synchronization error (Physical Layer Error)	Extra bytes are received before the start bytes (0x05 and 0x64).
11	DNP overrun error (Physical Layer Error)	Mainline Data Link Layer routine could not read data received on DNP port before it was overwritten.
12	DNP length error (Physical Layer Error)	Length of message does not match length value in message.
13	DNP bad CRC error (Data Link Layer Error)	Computed CRC value for message does not match that received in message.
14	DNP user data overflow error (Transport Layer Error)	Application layer received a message fragment buffer which is too small.
15	DNP sequence error (Transport Layer Error)	Sequence numbers of multi-frame request fragments do not increment correctly.
16	DNP address error (Transport Layer Error)	Source addresses contained in multi-frame request fragments do not match.
17	DNP bad function code error (Application Layer Error)	Function code received from DNP master is not supported for selected object/variation.
18	DNP object unknown error (Application Layer Error)	Slave does not have the specified objects or there are no objects assigned to the requested class.
19	DNP out of range error (Application Layer Error)	Qualifier, range or data fields are not valid or out of range for the selected object/variation.
20	DNP message overflow error (Application Layer Error)	Application response buffer overflow condition. The response message from the slave is too long to transmit.
21	DNP master multi-frame message error (Application Layer Error)	Received a multi-frame message from the DNP master. This application does not support multi-frame messages from the master.

5.10.2 System Configuration Errors

Error Code	Name	Description
100	Too many binary input points	Too many binary input points are configured for the module. Maximum value is 15360.
101	Too many binary output points	Too many binary output points are configured for the module. Maximum value is 15360.
102	Too many counter points	Too many counter points are configured for the module. Maximum value is 480.
103	Too many analog input points	Too many analog input points are configured for the module. Maximum value is 960.
104	Too many analog output points	Too many analog output points are configured for the module. Maximum value is 960.
105	Too many binary input events	Too many binary input events are configured for the module. Maximum value is 400.
106	Too many analog input events	Too many analog input events are configured for the module. Maximum value is 400.
107	Invalid analog input deadband	Deadband value for analog input events is out of range. Value must be in the range of 0 to 32767.
108	Not enough memory	There is not enough memory in the module to configure the module as specified.
109	Invalid block transfer delay for blocks 251 and 252 (error/status blocks)	Block transfer delay value specified is too low.
110	File count invalid	The file count must be in the range of 0 to 6.
111	Invalid file record size	The file record size must be in the range of 1 to 120.
112	Invalid block identification code for file	The file block transfer code must be in the range of 100 to 120.

5.10.3 DNP Port Configuration Errors

Error Code	Name	Description
212	Invalid DNP address	The DNP address specified in the configuration is not valid (0 to 65534).
213	Invalid DNP port baud rate	The baud rate code specified in the configuration is not valid.
219	Invalid DNP data link layer confirm mode	The data link confirmation mode code is not valid in the configuration.
220	Invalid DNP data link confirm time-out	The data link time-out period specified in the configuration is 0. It must be an integer in the range of 1 to 65535.
222	Invalid DNP select/operate arm time duration	The select/operate arm timer is set to 0. It must be an integer in the range of 1 to 65535.
223	Invalid DNP application layer confirm time-out	The application layer confirm time-out value is set to 0. It must be an integer in the range of 1 to 65535.

Error Code	Name	Description
224	Invalid DNP write time interval	The write time interval is not in the data range in the configuration. The value must be in the range of 0 to 1440.
225	Invalid DNP unsolicited response mode	The unsolicited response mode code is not valid in the configuration.
226	Invalid DNP unsolicited response minimum quantity for Class 1	The unsolicited response minimum quantity for Class 1 is not valid in the configuration. Value must be an integer in the range of 1 to 255.
227	Invalid DNP unsolicited response minimum quantity for Class 2	The unsolicited response minimum quantity for Class 2 is not valid in the configuration. Value must be an integer in the range of 1 to 255.
228	Invalid DNP unsolicited response minimum quantity for Class 3	The unsolicited response minimum quantity for Class 3 is not valid in the configuration. Value must be an integer in the range of 1 to 255.
230	Invalid DNP unsolicited response destination address	The unsolicited response destination address is not valid in the configuration. Value must be in the range of 1 to 65534.

5.11 Command Error Codes

5.11.1 General Command Errors

Error Code	Name	Description
-1 (65535)	Current command being issued on the port	Command has been issued out the port, and the module is waiting for the slave to respond.
0	OK	The command was issued and responded to correctly.
1	Device not defined	The IED slave address referenced in the command is not defined in the module. Check to make sure there is an entry in the slave table for each slave device referenced in the command list.
2	Invalid command	This command is not valid. Check to make sure the slave address parameter is greater than or equal to zero and that the point count is not set to zero.
3	Object not supported	The data object in the command is not supported by the module. Refer to the DNP subset for the Master Port.
4	Command function not supported	The function specified in the command is not supported for the object type selected. Refer to the DNP subset for the Master Port.
10	Invalid binary input poll command	This binary input object command is not valid.
11	Invalid binary input event poll command	This binary input event object poll command is not valid.
20	Invalid binary output command function	This binary output function command is not valid.
30	Invalid counter poll command function	The counter object poll command contains an invalid function code.

Error Code	Name	Description
31	Invalid counter poll command	This counter object poll command is not valid.
40	Invalid frozen counter poll command	This frozen counter object poll command is not valid.
50	Invalid analog input poll command	This analog input poll command is not valid.
51	Invalid analog input event poll command	This analog input event poll command is not valid.
60	Invalid analog output poll function command	This analog output poll command contains an invalid function code.
61	Invalid analog output poll command	This analog output poll command is not valid.
70	Invalid time/date poll command	This time/date object poll command is not valid.
80	Invalid event poll command	This event poll command is not valid.

5.11.2 Application Layer Errors

Error Code	Name	Description
1000	Device index invalid	The device index in the request or response message is not found in the slave list.
1001	Duplicate request in application layer queue	The newly submitted message to the application layer already exists in the queue. The message is ignored.
1002	COM port device removed from system	The communication port for the message has been uninstalled on the system. This error should never occur as the communication ports are only uninstalled when the module's program is terminated.
1003	Sequence number error	The application sequence number in the response message does not match that based on the last request message. This indicates application layer messages are received out of order.
1004	Response to select before operate does not match	The select response message received from the slave module is not that expected from the last select request. This indicates a synchronization problem between the master and slave devices.
1005	Response does not contain date/time object	The response message from the slave device does not contain a date/time object. The master expects this object for the response message.
1006	Time-out condition on response	The slave device did not respond to the last request message from the master within the time-out set for the IED device. The application layer time-out value is specified for each IED unit in the slave configuration table in the module. This table is established each time the module performs the restart operation.
1007	Function code in application layer message not supported	The function code returned in the response message is not valid for the application layer or not supported by the module.

Error Code	Name	Description
1008	Read operation not supported for object/variation	The application layer response message contains an object that does not support the read function.
1009	Operate function not supported for the object/variation	The application layer response message contains an object that does not support the operate function.
1010	Write operation not supported for the object/variation	The application layer response message contains an object that does not support the write function.

5.12 Event Size Computation

The minimum event buffer size required to avoid overflow can be computed as follows:

$$((\text{number of static points}) * (\text{rate per second scan of change function})) / (\text{rate per second of master event data poll})$$

For example: 51 binary input points are scanned 2 times each second and polled by the master station about every 5 seconds. The minimum number of binary input events is:

$$(51 * 2) / .02 = 510 \text{ events}$$

This computation assumes the unlikely event that all data points will change in consecutive calls to the scan of change function. If an event buffer overflow condition occurs, the internal indication bit, BUFFER OVERFLOW, will be set. If the system you are working with is fairly stable, the following equation can be used to compute the event buffer size:

$$(\text{number of points that change per change function} * \text{rate per second of scan of change function}) * (\text{number of seconds between master event data poll})$$

For example: 1000 binary input points are scanned 2 times each second and polled by the master station about every 5 seconds. Only about 5 points change state every scan of the change function call.

$$(5 * 2) * 5 = 50 \text{ events required}$$

The number of events that can be defined in the system is limited to 400. The event buffer will overflow in systems which are very dynamic unless one of the following conditions exist:

The master frequently polls the slave device for events to keep the buffer empty.

OR

The slave is configured to send unsolicited messages to the master station. This method requires full-duplex operation of the network because the slave may be sending a message during a request from the master station.

In order to disable the report by exception feature in the module, set the number of events to 0 for both the binary and analog input events in the configuration (N[]:5 and 6 in the system configuration block). This will cause the slave to never return any data on object 2 and 32 and class 2 and 3 master station requests.

5.13 Device Profile

DNP V3.00 DEVICE PROFILE DOCUMENT	
Vendor Name:	ProSoft Technology, Inc.
Device Name:	MVI71-DNP
Highest DNP Level Supported: For Request: L2 For Responses: L2	Device Function: Slave & Master
<p>Notable objects, functions, and/or qualifiers supported in addition to the highest DNP level stated above (attached table for complete list): Definition of selected IIN bits: Configuration Error -User specified point or event count is too high for application (can only correct by changing configuration in PLC).</p> <p>Support of Obj70Var1 is present on the module for slave only.</p> <p>Support for a redundant slave port on the module which may be attached to a dial-up modem is provided. Auto switching is provided by the module to switch between the primary and secondary</p> <p>The following features are configurable on the module: Collision avoidance, time sync before events are generated and default analog input events, Obj32V4 or O32V2, select option.</p> <p>Events generated by IED units attached to a master port may pass their events directly to the I port. These events may not occur in the correct time sequence. They are placed in the event buffer as the module receives them. This provides the greatest time resolution for remote events.</p> <p>Module will not generate events until Restart IIN bit is cleared by DNP master except for events through module from attached IED units.</p>	
Maximum Data Link Frame Size (octets): Transmitted: 292 Received: 292	Maximum Application Fragment Size Transmitted: 2048 Received: 2048 (octets):
Maximum Data Link Re-tries: Configurable from 0 -255	Maximum Application Layer Re-tries: None
Requires Data Link Layer Confirmation: Configurable at module start-up (never, sometimes, &always)	
Requires Application Layer Confirmation: When reporting Event Data as a slave unit	
Time-outs while waiting for:	
Data Link Confirm	: Configurable at module start-up (1 to 65535 milliseconds)
Complete Application Fragment	: Configurable at module start-up
Application Confirm	: Configurable at module start-up (1 to 65535 milliseconds)
Complete Application Response	: None
Sends/Executes Control Operations:	
WRITE Binary Outputs	: Never
SELECT/OPERATE	: Always
DIRECT OPERATE	: Always
DIRECT OPERATE-NO ACK	: Always
Count > 1	: Never
Pulse On	: Never
Pulse Off	: Never
Latch On	: Always
Latch Off	: Always
Queue	: Never
Clear Queue	: Never
Reports Binary Input Change Events when no specific variation requested: Only time-tagged	Reports time-tagged Binary Input Change Events when no specific variation requested: Binary Input Change with Time

DNP V3.00 DEVICE PROFILE DOCUMENT	
Sends Unsolicited Responses: This is configurable at module start-up. If the number of events for the Binary or Analog Input Events is greater than 0, unsolicited responses are supported. Use the Enable/Disable Unsolicited function code from the DNP master for control.	Sends Static Data in Unsolicited Responses: Never
Default Counter Object/Variation: Object: 20 Variation: 5	Counters Roll Over at: 32 Bits
Sends Multi-Fragment Responses: Yes	

5.14 Slave Unit Device Profile Object Subset

Object		Request		Response				Notes
Obj	Var	Description	Func Codes	Qual Codes (hex)	Func Codes	Qual Codes (hex)	Data Size (bits)	
1	0	Binary Input – All Variations	1	06			1	Slave will return variation 1 data
	1	Binary Input	1	06	129, 130	00, 01	1	Slave will return this variation
	2	Binary Input with Status			129, 130	00, 01	8	Slave will return Unknown Object to this request.
2	0	Binary Input Change – All Variations	1	06, 07, 08			56	Slave will return variation 2 data
	1	Binary Input Change Without Time	1	06, 07, 08	129, 130	17, 28	8	Slave will return this variation
	2	Binary Input Change With Time	1	06, 07, 08	129, 130	17, 28	56	Slave will return this variation
	3	Binary Input Change With Relative Time	1	06, 07, 08	129, 130	17, 28	24	Slave will parse this message and return no data
10	0	Binary Output – All Variations	1	06			8	Slave will return variation 2 data
	1	Binary Output					1	Slave will return Unknown Object to this request
	2	Binary Output Status	1	06	129, 130	00, 01	8	Slave will return this variation
12	0	Control Block – All Variations					88	Slave will use variation 1 control
	1	Control Relay Output Block	3, 4, 5, 6	17, 28	129	Echo of request	88	Slave will respond correctly to this variation

Object			Request		Response			Notes
Obj	Var	Description	Func Codes	Qual Codes (hex)	Func Codes	Qual Codes (hex)	Data Size (bits)	
	2	Pattern Control Block					88	Slave will return Unknown Object to this request.
	3	Pattern Mask					16	Slave will return Unknown Object to this request.
20	0	Binary Counter – All Variations	1, 7, 8, 9, 10	06			32	Slave will return variation 5 data
	1	32-Bit Binary Counter			129, 130	00, 01	40	Slave will return Unknown Object to this request
	2	16-Bit Binary Counter			129, 130	00, 01	24	Slave will return Unknown Object to this request
	3	32-Bit Delta Counter			129, 130	00, 01	40	Slave will return Unknown Object to this request
	4	16-Bit Delta Counter			129, 130	00, 01	24	Slave will return Unknown Object to this request
	5	32-Bit Binary Counter Without Flag	1, 7, 8, 9, 10	06	129, 130	00, 01	32	Slave will return this variation
	6	16-Bit Binary Counter Without Flag	1, 7, 8, 9, 10	06	129, 130	00, 01	16	Slave will return this variation (counter upper 16-bits removed)
	7	32-Bit Delta Counter Without Flag			129, 130	00, 01	32	Slave will return Unknown Object to this request
	8	16-Bit Delta Counter Without Flag			129, 130	00, 01	16	Slave will return Unknown Object to this request
21	0	Frozen Counter – All Variations	1	06			32	Slave will return variation 9 data
	1	32-Bit Frozen Counter			129, 130	00, 01	40	Slave will return Unknown Object to this request
	2	16-Bit Frozen Counter			129, 130	00, 01	24	Slave will return Unknown Object to this request
	3	32-Bit Frozen Delta Counter					40	Slave will return Unknown Object to this request
	4	16-Bit Frozen Delta Counter					24	Slave will return Unknown Object to this request

Object			Request		Response			Notes
Obj	Var	Description	Func Codes	Qual Codes (hex)	Func Codes	Qual Codes (hex)	Data Size (bits)	
	5	32-Bit Frozen Counter With Time Of Freeze					88	Slave will return Unknown Object to this request
	6	16-Bit Frozen Counter With Time Of Freeze					72	Slave will return Unknown Object to this request
	7	32-Bit Frozen Delta Counter With Time Of Freeze					88	Slave will return Unknown Object to this request
	8	16-Bit Frozen Delta Counter With Time Of Freeze					72	Slave will return Unknown Object to this request
	9	32-Bit Frozen Counter Without Flag	1	06	129, 130	00, 01	32	Slave will return this variation
	10	16-Bit Frozen Counter Without Flag	1	06	129, 130	00, 01	16	Slave will return this variation (counter upper 16-bits removed)
	11	32-Bit Frozen Delta Counter Without Flag					32	Slave will return Unknown Object to this request
	12	16-Bit Frozen Delta Counter Without Flag					16	Slave will return Unknown Object to this request
22	0	Counter Change Event – All Variations	1	06, 07, 08				Slave will parse this request and return no data
	1	32-Bit Counter Change Event Without Time			129, 130	17, 28	40	Slave will return Unknown Object to this request
	2	16-Bit Counter Change Event Without Time			129, 130	17, 28	24	Slave will return Unknown Object to this request
	3	32-Bit Delta Counter Change Event Without Time					40	Slave will return Unknown Object to this request
	4	16-Bit Delta Counter Change Event Without Time					24	Slave will return Unknown Object to this request
	5	32-Bit Counter Change Event With Time					88	Slave will return Unknown Object to this request

Object			Request		Response			Notes
Obj	Var	Description	Func Codes	Qual Codes (hex)	Func Codes	Qual Codes (hex)	Data Size (bits)	
	6	16-Bit Counter Change Event With Time					72	Slave will return Unknown Object to this request
	7	32-Bit Delta Counter Change Event With Time					88	Slave will return Unknown Object to this request
	8	16-Bit Delta Counter Change Event With Time					72	Slave will return Unknown Object to this request
23	0	Frozen Counter Event – All Variations						Slave will return Unknown Object to this request
	1	32-Bit Frozen Counter Event Without Time					40	Slave will return Unknown Object to this request
	2	16-Bit Frozen Counter Event Without Time					24	Slave will return Unknown Object to this request
	3	32-Bit Frozen Delta Counter Event Without Time					40	Slave will return Unknown Object to this request
	4	16-Bit Frozen Delta Counter Event Without Time					24	Slave will return Unknown Object to this request
	5	32-Bit Frozen Counter Event With Time					88	Slave will return Unknown Object to this request
	6	16-Bit Frozen Counter Event With Time					72	Slave will return Unknown Object to this request
	7	32-Bit Frozen Delta Counter Event With Time					88	Slave will return Unknown Object to this request
	8	16-Bit Frozen Delta Counter Event With Time					72	Slave will return Unknown Object to this request
30	0	Analog Input – All Variations	1	06			16	Slave will respond with variation 4 data
	1	32-Bit Analog Input	1	06	129, 130	00, 01	40	Slave will return this variation (Note: Data will only be 16-bit)
	2	16-Bit Analog Input	1	06	129, 130	00, 01	24	Slave will return this variation

Object			Request		Response			Notes
Obj	Var	Description	Func Codes	Qual Codes (hex)	Func Codes	Qual Codes (hex)	Data Size (bits)	
	3	32-Bit Analog Input Without Flag	1	06	129, 130	00, 01	32	Slave will return this variation (Note: Data will only be 16-bit)
	4	16-Bit Analog Input Without Flag	1	06	129, 130	00, 01	16	Slave will return this variation
	5	32-bit Float	1	06	129, 130	00, 01	32	Slave will return this variation
31	0	Frozen Analog Input – All Variations						Slave will return Unknown Object to this request
	1	32-Bit Frozen Analog Input					40	Slave will return Unknown Object to this request
	2	16-Bit Frozen Analog Input					24	Slave will return Unknown Object to this request
	3	32-Bit Frozen Analog Input With Time To Freeze					88	Slave will return Unknown Object to this request
	4	16-Bit Frozen Analog Input With Time To Freeze					72	Slave will return Unknown Object to this request
	5	32-Bit Frozen Analog Input Without Flag					32	Slave will return Unknown Object to this request
	6	16-Bit Frozen Analog Input Without Flag					16	Slave will return Unknown Object to this request
32	0	Analog Change Event – All Variations	1	06, 07, 08			24	Slave will return variation 2 data
	1	32-Bit Analog Change Event Without Time	1	06, 07, 08	129, 130	17, 28	40	Slave will return this variation (Note: Data only 16-bit)
	2	16-Bit Analog Change Event Without Time	1	06, 07, 08	129, 130	17, 28	24	Slave will return this variation
	3	32-Bit Analog Change Event With Time	1	06, 07, 08	129, 130	17, 28	88	Slave will return this variation (Note: Data only 16-bit)
	4	16-Bit Analog Change Event With Time	1	06, 07, 08	129, 130	17, 28	72	Slave will return this variation
33	0	Frozen Analog Event – All Variations						Slave will return Unknown Object to this request

Object			Request		Response			Notes
Obj	Var	Description	Func Codes	Qual Codes (hex)	Func Codes	Qual Codes (hex)	Data Size (bits)	
	1	32-Bit Frozen Analog Event Without Time					40	Slave will return Unknown Object to this request
	2	16-Bit Frozen Analog Event Without Time					24	Slave will return Unknown Object to this request
	3	32-Bit Frozen Analog Event With Time					88	Slave will return Unknown Object to this request
	4	16-Bit Frozen Analog Event With Time					72	Slave will return Unknown Object to this request
40	0	Analog Output Status – All Variations	1	06			24	Slave will return variation 2 data
	1	32-Bit Analog Output Status	1	06	129,130	00,01	40	Slave will return this variation but data only 16-bit accuracy
	2	16-Bit Analog Output Status	1	06	129, 130	00, 01	24	Slave will return this variation
41	0	Analog Output Block – All Variations					24	Slave will respond to this request using variation 2 data
	1	32-Bit Analog Output Block	3, 4, 5, 6	17, 28	129,130	00,01	40	Slave will respond to this request but data only 16-bit
	2	16-Bit Analog Output Block	3, 4, 5, 6	17, 28	129	Echo of Request	24	Slave will respond to this request
50	0	Time and Date – All Variations	2	07, With Quant=1			48	Slave will use variation 1
	1	Time and Date	2	07, With Quant=1			48	Slave will respond to this variation
	2	Time and Date With Interval					80	Slave will return Unknown Object to this request
51	0	Time and Date CTO – All Variations						Slave will return Unknown Object to this request
	1	Time and Date CTO			129, 130	07, With Quant=1	48	Slave will return Unknown Object to this request
	2	Unsynchronized Time and Date CTO			129, 130	07, With Quant=1	48	Slave will return Unknown Object to this request
52	0	Time Delay – All Variations						
	1	Time Delay Coarse			129	07, With Quant=1	16	Slave will never return this variation

Object			Request		Response			Notes
Obj	Var	Description	Func Codes	Qual Codes (hex)	Func Codes	Qual Codes (hex)	Data Size (bits)	
	2	Time Delay Fine			129	07, With Quant=1	16	Slave will return this variation to functions 0D, 0E, and 17
60	0	Not Defined						Not Defined in DNP
	1	Class 0 Data	1	06				Slave will respond to this variation will all static data
	2	Class 1 Data	1	06, 07, 08				Slave will respond to this variation (No class 1 data defined in application)
	3	Class 2 Data	1	06, 07, 08				Slave will respond to this variation will all class 2 data (binary input events)
	4	Class 3 Data	1	06, 07, 08				Slave will respond to this variation will all class 3 data (analog input events)
70	0	Not Defined						
	1	File Identifier						
80	0	Not Defined						Not Defined in DNP
	1	Internal Indications	2	00, Index=7			24	Slave will respond to this variation
81	0	Not Defined						Not Defined in DNP
	1	Storage Object						
82	0	Not Defined						Not Defined in DNP
	1	Device Profile						
83	0	Not Defined						Not Defined in DNP
	1	Private Registration Object						
	2	Private Registration Objection Descriptor						
90	0	Not Defined						Not Defined in DNP
	1	Application Identifier						
100	0							
	1	Short Floating Point					48	

Object		Request Description	Request		Response			Notes
Obj	Var		Func Codes	Qual Codes (hex)	Func Codes	Qual Codes (hex)	Data Size (bits)	
	2	Long Floating Point					80	
	3	Extended Floating Point					88	
101	0							
	1	Small Packed Binary-Coded Decimal					16	
	2	Medium Packed Binary-Coded Decimal					32	
	3	Large Packed Binary-Coded Decimal					64	
No Object			13					Slave supports the Cold Restart Function and will return Obj 52, Var 2, Qual 7, Cnt 1
			14					Slave supports the Warm Restart Function and will return Obj 52, Var 2, Qual 7, Cnt 1
			20					Slave supports the Enable Unsolicited Function
			21					Slave supports the Disable Unsolicited Function
			23					Slave supports the Delay Measurement & Time Synchronization Function and will return Obj 52, Var 2, Qual 7, Cnt 1

5.15 Master Unit Device Profile Object Subset

Object			Request		Response			Notes
Obj	Var	Description	Func Codes	Qual Codes (hex)	Func Codes	Qual Codes (hex)	Data Size (bits)	
1	0	Binary Input – All Variations	1	06			1	Master will generate this variation.
	1	Binary Input	1	06	129, 130	00, 01	1	Master will generate and process this variation.
	2	Binary Input with Status	1	06	129, 130	00, 01	8	Master will generate and process this variation.
2	0	Binary Input Change – All Variations	1	06, 07, 08			56	Master will generate this variation.
	1	Binary Input Change Without Time	1	06, 07, 08	129, 130	17, 28	8	Master will generate and process this variation.
	2	Binary Input Change With Time	1	06, 07, 08	129, 130	17, 28	56	Master will generate and process this variation.
	3	Binary Input Change With Relative Time	1	06, 07, 08	129, 130	17, 28	24	Master will generate and process this variation.
10	0	Binary Output – All Variations	1	06			8	Master does not use this object type and will not generate a message or process this type.
	1	Binary Output					1	
	2	Binary Output Status			129, 130	00, 01	8	
12	0	Control Block – All Variations					88	
	1	Control Relay Output Block	3, 4, 5, 6	17, 28	129	Echo of request	88	Master will generate this variation and parse the response.
	2	Pattern Control Block					88	
	3	Pattern Mask					16	
20	0	Binary Counter – All Variations	1, 7, 8, 9, 10	06			32	Master will generate this variation.

Object		Description	Request		Response			Notes
Obj	Var		Func Codes	Qual Codes (hex)	Func Codes	Qual Codes (hex)	Data Size (bits)	
	1	32-Bit Binary Counter			129, 130	00, 01	40	Master will process this variation.
	2	16-Bit Binary Counter			129, 130	00, 01	24	Master will process this variation.
	3	32-Bit Delta Counter			129, 130	00, 01	40	Master will process this variation.
	4	16-Bit Delta Counter			129, 130	00, 01	24	Master will process this variation.
	5	32-Bit Binary Counter Without Flag	1, 7, 8, 9, 10	06	129, 130	00, 01	32	Master will generate and process this variation.
	6	16-Bit Binary Counter Without Flag	1, 7, 8, 9, 10	06	129, 130	00, 01	16	Master will generate and process this variation.
	7	32-Bit Delta Counter Without Flag			129, 130	00, 01	32	Master will process this variation.
	8	16-Bit Delta Counter Without Flag			129, 130	00, 01	16	Master will process this variation.
21	0	Frozen Counter – All Variations	1	06			32	Master will generate this variation.
	1	32-Bit Frozen Counter			129, 130	00, 01	40	Master will process this variation.
	2	16-Bit Frozen Counter			129, 130	00, 01	24	Master will process this variation.
	3	32-Bit Frozen Delta Counter					40	
	4	16-Bit Frozen Delta Counter					24	
	5	32-Bit Frozen Counter With Time Of Freeze					88	
	6	16-Bit Frozen Counter With Time Of Freeze					72	
	7	32-Bit Frozen Delta Counter With Time Of Freeze					88	

Object		Description	Request		Response			Notes
Obj	Var		Func Codes	Qual Codes (hex)	Func Codes	Qual Codes (hex)	Data Size (bits)	
	8	16-Bit Frozen Delta Counter With Time Of Freeze					72	
	9	32-Bit Frozen Counter Without Flag	1	06	129, 130	00, 01	32	Master will generate and process this variation.
	10	16-Bit Frozen Counter Without Flag	1	06	129, 130	00, 01	16	Master will generate and process this variation.
	11	32-Bit Frozen Delta Counter Without Flag					32	
	12	16-Bit Frozen Delta Counter Without Flag					16	
22	0	Counter Change Event – All Variations	1	06, 07, 08				Master will not generate a request for this variation.
	1	32-Bit Counter Change Event Without Time			129, 130	17, 28	40	Master will process this variation.
	2	16-Bit Counter Change Event Without Time			129, 130	17, 28	24	Master will process this variation.
	3	32-Bit Delta Counter Change Event Without Time					40	
	4	16-Bit Delta Counter Change Event Without Time					24	
	5	32-Bit Counter Change Event With Time					88	
	6	16-Bit Counter Change Event With Time					72	
	7	32-Bit Delta Counter Change Event With Time					88	
	8	16-Bit Delta Counter Change Event With Time					72	
23	0	Frozen Counter Event – All Variations						

Object		Description	Request		Response			Notes
Obj	Var		Func Codes	Qual Codes (hex)	Func Codes	Qual Codes (hex)	Data Size (bits)	
	1	32-Bit Frozen Counter Event Without Time					40	
	2	16-Bit Frozen Counter Event Without Time					24	
	3	32-Bit Frozen Delta Counter Event Without Time					40	
	4	16-Bit Frozen Delta Counter Event Without Time					24	
	5	32-Bit Frozen Counter Event With Time					88	
	6	16-Bit Frozen Counter Event With Time					72	
	7	32-Bit Frozen Delta Counter Event With Time					88	
	8	16-Bit Frozen Delta Counter Event With Time					72	
30	0	Analog Input – All Variations	1	06			16	Master will generate this variation.
	1	32-Bit Analog Input	1	06	129, 130	00, 01	40	Master will generate this variation. Note: Data returned will only be Least Significant 16 bits from Slave
	2	16-Bit Analog Input	1	06	129, 130	00, 01	24	Master will generate and process this variation.
	3	32-Bit Analog Input Without Flag	1	06	129, 130	00, 01	32	Master will generate this variation. Note: Data returned will only be Least Significant 16 bits from Slave

Object			Request		Response			Notes
Obj	Var	Description	Func Codes	Qual Codes (hex)	Func Codes	Qual Codes (hex)	Data Size (bits)	
	4	16-Bit Analog Input Without Flag	1	06	129, 130	00, 01	16	Master will generate and process this variation.
31	0	Frozen Analog Input – All Variations						
	1	32-Bit Frozen Analog Input					40	
	2	16-Bit Frozen Analog Input					24	
	3	32-Bit Frozen Analog Input With Time To Freeze					88	
	4	16-Bit Frozen Analog Input With Time To Freeze					72	
	5	32-Bit Frozen Analog Input Without Flag					32	
	6	16-Bit Frozen Analog Input Without Flag					16	
32	0	Analog Change Event – All Variations	1	06, 07, 08			24	Master will generate this variation
	1	32-Bit Analog Change Event Without Time	1	06, 07, 08	129, 130	17, 28	40	Master will generate and process this variation (16 bit data).
	2	16-Bit Analog Change Event Without Time	1	06, 07, 08	129, 130	17, 28	24	Master will generate and process this variation.
	3	32-Bit Analog Change Event With Time	1	06, 07, 08	129, 130	17, 28	88	Master will generate and process this variation (16 bit data).
	4	16-Bit Analog Change Event With Time	1	06, 07, 08	129, 130	17, 28	72	Master will generate and process this variation.
33	0	Frozen Analog Event – All Variations						
	1	32-Bit Frozen Analog Event Without Time					40	

Object		Description	Request		Response			Notes
Obj	Var		Func Codes	Qual Codes (hex)	Func Codes	Qual Codes (hex)	Data Size (bits)	
	2	16-Bit Frozen Analog Event Without Time					24	
	3	32-Bit Frozen Analog Event With Time					88	
	4	16-Bit Frozen Analog Event With Time					72	
40	0	Analog Output Status – All Variations	1	06			24	Master does not use this object type and will not generate a message or process this type.
	1	32-Bit Analog Output Status					40	
	2	16-Bit Analog Output Status			129, 130	00, 01	24	
41	0	Analog Output Block - All Variations					24	
	1	32-Bit Analog Output Block					40	
	2	16-Bit Analog Output Block	3, 4, 5, 6	17, 28	129	Echo of Request	24	Master will generate this variation and parse the response.
50	0	Time and Date – All Variations					48	
	1	Time and Date	2	07, With Quant=1			48	Master will generate this variation.
	2	Time and Date With Interval					80	
51	0	Time and Date CTO – All Variations						
	1	Time and Date CTO			129, 130	07, With Quant=1	48	Master will process this variation.
	2	Unsynchronized Time and Date CTO			129, 130	07, With Quant=1	48	Master will process this variation.
52	0	Time Delay - All Variations						
	1	Time Delay Coarse			129	07, With Quant=1	16	Master will not process this variation.
	2	Time Delay Fine			129	07, With Quant=1	16	Master will not process this variation.

Object		Description	Request		Response			Notes
Obj	Var		Func Codes	Qual Codes (hex)	Func Codes	Qual Codes (hex)	Data Size (bits)	
60	0	Not Defined						Not Defined in DNP
	1	Class 0 Data	1	06				Master will generate this variation.
	2	Class 1 Data	1	06, 07, 08				Master will generate this variation.
	3	Class 2 Data	1	06, 07, 08				Master will generate this variation.
	4	Class 3 Data	1	06, 07, 08				Master will generate this variation.
70	0	Not Defined						
	1	File Identifier						
80	0	Not Defined						
	1	Internal Indications	2	00, Index=7			24	The Master will generate this variation.
81	0	Not Defined						
	1	Storage Object						
82	0	Not Defined						
	1	Device Profile						
83	0	Not Defined						Not Defined in DNP
	1	Private Registration Object						
	2	Private Registration Objection Descriptor						
90	0	Not Defined						Not Defined in DNP
	1	Application Identifier						
100	0							
	1	Short Floating Point					48	
	2	Long Floating Point					80	
	3	Extended Floating Point					88	
101	0							
	1	Small Packed Binary-Coded Decimal					16	
	2	Medium Packed Binary-Coded Decimal					32	

Object			Request		Response			
Obj	Var	Description	Func Codes	Qual Codes (hex)	Func Codes	Qual Codes (hex)	Data Size (bits)	Notes
	3	Large Packed Binary-Coded Decimal					64	
No Object			13					Master supports the Cold Restart Function
			14					Master supports the Warm Restart Function
			20					Master supports the Enable Unsolicited Function
			21					Master supports the Disable Unsolicited Function

6 ProSoft Technology, Inc., Support, Service & Warranty

In This Chapter

- How to Contact Us: Sales and Support..... 160
- Return Material Authorization (RMA) Policies and Conditions 161
- Procedures for Return of Units Under Warranty..... 161
- Procedures for Return of Units Out of Warranty..... 162
- LIMITED WARRANTY 163

Be sure and read the full Warranty that can be found on our web site at www.prosoft-technology.com for details and other terms and conditions. The content in this summary is subject to change without notice. The content is current at date of publication.

ProSoft Technology, Inc. strives to provide meaningful support to its customers. Should any questions or problems arise, please feel free to contact us at:

InternetWeb Site: <http://www.prosoft-technology.com/support>E-mail address: support@prosoft-technology.com

Those of us at ProSoft Technology, Inc. want to provide the best and quickest support possible, so before calling please have the following information available. You may wish to fax this information to us prior to calling.

- 1 Product Version Number
- 2 System architecture
- 3 Network details

In the case of hardware, we will also need the following information:

- 1 Module configuration and contents of file
- 2 Module Operation
- 3 Configuration/Debug status information
- 4 LED patterns
- 5 Information about the processor and user data files as viewed through the development software and LED patterns on the processor
- 6 Details about the networked devices interfaced, if any

For technical support calls within the United States, an after-hours answering system allows pager access to one of our qualified technical and/or application support engineers at any time to answer your questions.

6.1 How to Contact Us: Sales and Support

All ProSoft Technology Products are backed with full technical support. Contact our worldwide Technical Support team and Customer Service representatives directly by phone or email:

USA / Latin America (excluding Brasil) (Office in California)

+1(661) 716-5100
+1(661) 716-5101 (Fax)
1675 Chester Avenue, 4th Floor
Bakersfield, California 93301
U.S.A.
+1.661.716.5100, support@prosoft-technology.com
Languages spoken include: English, Spanish

Asia Pacific (office in Malaysia)

+603.7724.2080
+603.7724.2090 (Fax)
C210, Damansara Intan,
1 Jalan SS20/27, 47400 Petaling Jaya
Selangor, Malaysia
+603.7724.2080, asiapc@prosoft-technology.com
Languages spoken include: Chinese, Japanese, English

China Pacific (office in China)

+86.21.64518356 x 8011
+86.21.64756957 (Fax)
4/F, No. 16 Hongcao Road
Shanghai, China 200233
China
+86.21.64518356 x 8011, zhang@prosoft-technology.com
Languages spoken include: Chinese, English

Europe / Middle East / Africa (office in Toulouse, France)

+33 (0) 5.34.36.87.20
+33 (0) 5.61.78.40.52 (Fax)
Zone d'activité de Font Grasse
17, rue des Briquetiers
F-31700 Blagnac
France
+33 (0) 5.34.36.87.20. support. EMEA@prosoft-technology.com
Languages spoken include: French, English

Brasil (office in Sao Paulo)

+55-11-5084-5178
+55-11-5083-3776 (Fax)
Rua Vergueiro, 2949 - sala 182 - Edifício Vergueiro Work Center
Vila Mariana - São Paulo
Cep: 04101-300 – Brasil
+55-11-5084-5178, eduardo@prosoft-technology.com
Languages spoken include: Portuguese, English

6.2 Return Material Authorization (RMA) Policies and Conditions

The following RMA Policies and Conditions apply to any returned product. These RMA Policies are subject to change by ProSoft without notice. For warranty information, see Section C below entitled "Limited Warranty". In the event of any inconsistency between the RMA Policies and the Warranty, the Warranty shall govern.

6.2.1 All Product Returns

- 1 In order to return a Product for repair, exchange or otherwise, the Customer must obtain a Returned Material Authorization (RMA) number from ProSoft and comply with ProSoft shipping instructions.
- 2 In the event that the Customer experiences a problem with the Product for any reason, Customer should contact ProSoft Technical Support at one of the telephone numbers listed above in Section A. A Technical Support Engineer will request several tests in an attempt to isolate the problem. If after these tests are completed, the Product is found to be the source of the problem, ProSoft will issue an RMA.
- 3 All returned Products must be shipped freight prepaid, in the original shipping container or equivalent, to the location specified by ProSoft, and be accompanied by proof of purchase. The RMA number is to be prominently marked on the outside of the shipping box. Customer agrees to insure the Product or assume the risk of loss or damage in transit. Products shipped to ProSoft without an RMA number will be returned to the Customer, freight collect. Contact ProSoft Technical Support for further information.
- 4 Out of warranty returns are not allowed on RadioLinx accessories such as antennas, cables, and brackets.

The following policy applies for Non-Warranty Credit Returns:

- A 10% Restocking Fee if Factory Seal is *not* broken
- B 20% Restocking Fee if Factory Seal is broken

ProSoft retains the right, in its absolute and sole discretion, to reject any non-warranty returns for credit if the return is not requested within three (3) months after shipment of the Product to Customer, if the Customer fails to comply with ProSoft's shipping instructions, or if the Customer fails to return the Product to ProSoft within six (6) months after Product was originally shipped.

6.3 Procedures for Return of Units Under Warranty

- 1 A Technical Support Engineer must pre-approve all product returns.
- 2 Module is repaired or replaced after a Return Material Authorization Number is entered and a replacement order is generated.
- 3 Credit for the warranted item is issued within 10 business days after receipt of product and evaluation of the defect has been performed by ProSoft. The credit will only be issued provided the product is returned with a valid Return Material Authorization Number and in accordance with ProSoft's shipping instructions.
 - a) If no defect is found, a credit is issued.

- b) If a defect is found and is determined to be customer generated or if the defect is otherwise not covered by ProSoft's Warranty, or if the module is not repairable, a credit is not issued and payment of the replacement module is due.

6.4 Procedures for Return of Units Out of Warranty

- 1 Customer sends unit in for evaluation.
- 2 If no defect is found, Customer will be charged the equivalent of US \$100 plus shipping, duties and taxes that may apply. A new Purchase Order will be required for this evaluation fee.
If the unit is repaired the charge to the Customer will be 30%* of the list price plus any shipping, duties and taxes that may apply. A new Purchase Order will be required for a product repair.
- 3 For an immediate exchange, a new module may be purchased and sent to Customer while repair work is being performed. Credit for purchase of the new module will be issued when the new module is returned in accordance with ProSoft's shipping instructions and subject to ProSoft's policy on non-warranty returns. This is in addition to charges for repair of the old module and any associated charges to Customer.
- 4 If, upon contacting ProSoft Customer Service, the Customer is informed that unit is believed to be unrepairable, the Customer may choose to send unit in for evaluation to determine if the repair can be made. Customer will pay shipping, duties and taxes that may apply. If unit cannot be repaired, the Customer may purchase a new unit.

6.4.1 Un-repairable Units

- 3150-All
- 3750
- 3600-All
- 3700
- 3170-All
- 3250
- 1560 can be repaired, if defect is the power supply
- 1550 can be repaired, if defect is the power supply
- 3350
- 3300
- 1500-All

*** 30% of list price is an estimated repair cost only. The actual cost of repairs will be determined when the module is received by ProSoft and evaluated for needed repairs.**

6.4.2 Purchasing Warranty Extension

As detailed below in ProSoft's Warranty, the standard Warranty Period is one year (or in the case of RadioLinx modules, three years) from the date of delivery. The Warranty Period may be extended for an additional charge, as follows:

- Additional 1 year = 10% of list price
- Additional 2 years = 20% of list price
- Additional 3 years = 30% of list price

6.5 LIMITED WARRANTY

This Limited Warranty ("Warranty") governs all sales of hardware, software and other products (collectively, "Product") manufactured and/or offered for sale by ProSoft, and all related services provided by ProSoft, including maintenance, repair, warranty exchange, and service programs (collectively, "Services"). By purchasing or using the Product or Services, the individual or entity purchasing or using the Product or Services ("Customer") agrees to all of the terms and provisions (collectively, the "Terms") of this Limited Warranty. All sales of software or other intellectual property are, in addition, subject to any license agreement accompanying such software or other intellectual property.

6.5.1 What Is Covered By This Warranty

- A** *Warranty On New Products:* ProSoft warrants, to the original purchaser only, that the Product that is the subject of the sale will (1) conform to and perform in accordance with published specifications prepared, approved, and issued by ProSoft, and (2) will be free from defects in material or workmanship; provided these warranties only cover Product that is sold as new. This Warranty expires one year (or in the case of RadioLinx modules, three years) from the date of shipment (the "Warranty Period"). If the Customer discovers within the Warranty Period a failure of the Product to conform to specifications, or a defect in material or workmanship of the Product, the Customer must promptly notify ProSoft by fax, email or telephone. In no event may that notification be received by ProSoft later than 15 months (or in the case of RadioLinx modules, 39 months) from the date of delivery. Within a reasonable time after notification, ProSoft will correct any failure of the Product to conform to specifications or any defect in material or workmanship of the Product, with either new or used replacement parts. Such repair, including both parts and labor, will be performed at ProSoft's expense. All warranty service will be performed at service centers designated by ProSoft. If ProSoft is unable to repair the Product to conform to this Warranty after a reasonable number of attempts, ProSoft will provide, at its option, one of the following: a replacement product, a full refund of the purchase price or a credit in the amount of the purchase price. All replaced product and parts become the property of ProSoft. These remedies are the Customer's only remedies for breach of warranty.

- B** *Warranty On Services:* Material and labor used by ProSoft to repair a verified malfunction or defect are warranted on the terms specified above for new Product, provided said warranty will be for the period remaining on the original new equipment warranty or, if the original warranty is no longer in effect, for a period of 90 days from the date of repair.
- C** The Warranty Period for RadioLinx accessories (such as antennas, cables, brackets, etc.) are the same as for RadioLinx modules, that is, three years from the date of shipment.

6.5.2 What Is Not Covered By This Warranty

- A** ProSoft makes no representation or warranty, expressed or implied, that the operation of software purchased from ProSoft will be uninterrupted or error free or that the functions contained in the software will meet or satisfy the purchaser's intended use or requirements; the Customer assumes complete responsibility for decisions made or actions taken based on information obtained using ProSoft software.
- B** With the exception of RadioLinx accessories referenced in paragraph 1(c) this Warranty does not cover any product, components, or parts not manufactured by ProSoft.
- C** This Warranty also does not cover the failure of the Product to perform specified functions, or any other non-conformance, defects, losses or damages caused by or attributable to any of the following: (i) shipping; (ii) improper installation or other failure of Customer to adhere to ProSoft's specifications or instructions; (iii) unauthorized repair or maintenance; (iv) attachments, equipment, options, parts, software, or user-created programming (including, but not limited to, programs developed with any IEC 61131-3 programming languages, or "C") not furnished by ProSoft; (v) use of the Product for purposes other than those for which it was designed; (vi) any other abuse, misapplication, neglect or misuse by the Customer; (vii) accident, improper testing or causes external to the Product such as, but not limited to, exposure to extremes of temperature or humidity, power failure or power surges outside of the limits indicated on the product specifications; or (viii) disasters such as fire, flood, earthquake, wind or lightning.
- D** The information in this Agreement is subject to change without notice. ProSoft shall not be liable for technical or editorial errors or omissions made herein; nor for incidental or consequential damages resulting from the furnishing, performance or use of this material. The user guides included with your original product purchased by you from ProSoft, contains information protected by copyright. No part of the guide may be duplicated or reproduced in any form without prior written consent from ProSoft.

6.5.3 *DISCLAIMER REGARDING HIGH RISK ACTIVITIES*

PRODUCT MANUFACTURED OR SUPPLIED BY PROSOFT IS NOT FAULT TOLERANT AND IS NOT DESIGNED, MANUFACTURED OR INTENDED FOR USE IN HAZARDOUS ENVIRONMENTS REQUIRING FAIL-SAFE PERFORMANCE (INCLUDING, WITHOUT LIMITATION, THE OPERATION OF NUCLEAR FACILITIES, AIRCRAFT NAVIGATION OF COMMUNICATION SYSTEMS, AIR TRAFFIC CONTROL, DIRECT LIFE SUPPORT MACHINES OR WEAPONS SYSTEMS), IN WHICH THE FAILURE OF THE PRODUCT COULD LEAD DIRECTLY OR INDIRECTLY TO DEATH, PERSONAL INJURY, OR SEVERE PHYSICAL OR ENVIRONMENTAL DAMAGE (COLLECTIVELY, "HIGH RISK ACTIVITIES"). PROSOFT SPECIFICALLY DISCLAIMS ANY EXPRESS OR IMPLIED WARRANTY OF FITNESS FOR HIGH RISK ACTIVITIES.

6.5.4 *DISCLAIMER OF ALL OTHER WARRANTIES*

THE WARRANTIES SET FORTH IN PARAGRAPH 1 ABOVE ARE IN LIEU OF ALL OTHER WARRANTIES, EXPRESS OR IMPLIED, INCLUDING BUT NOT LIMITED TO THE IMPLIED WARRANTIES OF MERCHANTABILITY AND FITNESS FOR A PARTICULAR PURPOSE.

6.5.5 *LIMITATION OF REMEDIES***

IN NO EVENT WILL PROSOFT (OR ITS DEALER) BE LIABLE FOR ANY SPECIAL, INCIDENTAL, OR CONSEQUENTIAL DAMAGES BASED ON BREACH OF WARRANTY, BREACH OF CONTRACT, NEGLIGENCE, STRICT TORT, OR ANY OTHER LEGAL THEORY. DAMAGES THAT PROSOFT AND ITS DEALER WILL NOT BE RESPONSIBLE FOR INCLUDE, BUT ARE NOT LIMITED TO: LOSS OF PROFITS; LOSS OF SAVINGS OR REVENUE; LOSS OF USE OF THE PRODUCT OR ANY ASSOCIATED EQUIPMENT; LOSS OF DATA; COST OF CAPITAL; COST OF ANY SUBSTITUTE EQUIPMENT, FACILITIES, OR SERVICES; DOWNTIME; THE CLAIMS OF THIRD PARTIES, INCLUDING CUSTOMERS OF THE PURCHASER; AND INJURY TO PROPERTY.

**** Some areas do not allow time limitations on an implied warranty, or allow the exclusion or limitation of incidental or consequential damages. In such areas the above limitations may not apply. This Warranty gives you specific legal rights, and you may also have other rights which vary from place to place.**

6.5.6 *Time Limit for Bringing Suit*

Any action for breach of warranty must be commenced within 15 months (or in the case of RadioLinx modules, 39 months) following shipment of the Product.

6.5.7 No Other Warranties

Unless modified in writing and signed by both parties, this Warranty is understood to be the complete and exclusive agreement between the parties, suspending all oral or written prior agreements and all other communications between the parties relating to the subject matter of this Warranty, including statements made by salesperson. No employee of ProSoft or any other party is authorized to make any warranty in addition to those made in this Warranty. The Customer is warned, therefore, to check this Warranty carefully to see that it correctly reflects those terms that are important to the Customer.

6.5.8 Intellectual Property

- A** Any documentation included with Product purchased from ProSoft is protected by copyright and may not be photocopied or reproduced in any form without prior written consent from ProSoft.
- B** ProSoft's technical specifications and documentation that are included with the Product are subject to editing and modification without notice.
- C** Transfer of title shall not operate to convey to Customer any right to make, or have made, any Product supplied by ProSoft.
- D** Customer is granted no right or license to use any software or other intellectual property in any manner or for any purpose not expressly permitted by any license agreement accompanying such software or other intellectual property.
- E** Customer agrees that it shall not, and shall not authorize others to, copy software provided by ProSoft (except as expressly permitted in any license agreement accompanying such software); transfer software to a third party separately from the Product; modify, alter, translate, decode, decompile, disassemble, reverse-engineer or otherwise attempt to derive the source code of the software or create derivative works based on the software; export the software or underlying technology in contravention of applicable US and international export laws and regulations; or use the software other than as authorized in connection with use of Product.

6.5.9 Additional Restrictions Relating To Software And Other Intellectual Property

In addition to complying with the Terms of this Warranty, Customers purchasing software or other intellectual property shall comply with any license agreement accompanying such software or other intellectual property. Failure to do so may void this Warranty with respect to such software and/or other intellectual property.

6.5.10 Allocation of risks

This Warranty allocates the risk of product failure between ProSoft and the Customer. This allocation is recognized by both parties and is reflected in the price of the goods. The Customer acknowledges that it has read this Warranty, understands it, and is bound by its Terms.

6.5.11 Controlling Law and Severability

This Warranty shall be governed by and construed in accordance with the laws of the United States and the domestic laws of the State of California, without reference to its conflicts of law provisions. If for any reason a court of competent jurisdiction finds any provisions of this Warranty, or a portion thereof, to be unenforceable, that provision shall be enforced to the maximum extent permissible and the remainder of this Warranty shall remain in full force and effect. Any cause of action with respect to the Product or Services must be instituted in a court of competent jurisdiction in the State of California.

Index

I

[DNP Master Commands] • 41
 [DNP Master Slave List] • 41
 [DNP Master] • 39
 [DNP Slave Analog Inputs] • 36
 [DNP Slave Binary Inputs] • 36
 [DNP Slave Database] • 34
 [DNP Slave Float Inputs] • 37
 [DNP Slave] • 27
 [IED Database] • 40
 [Module] • 27
 [Secondary Port] • 37

A

Additional Restrictions Relating To Software
 And Other Intellectual Property • 166
 Address In Slave • 49
 AI Class • 31
 AI Deadband • 31
 AI Events with Time • 33
 All Product Returns • 161
 Allocation of risks • 166
 Analog Inputs • 34, 40
 Analog Inputs (60 points/block) • 119
 Analog Outputs • 35, 40
 Analog Outputs (60 points/block) • 120
 App Layer Confirm Tout • 32
 Application Layer Errors • 139

B

Backplane Data Transfer • 79
 Baud Rate • 29, 38
 BI Class • 30
 Binary Input Command Examples • 44
 Binary Inputs • 34, 40
 Binary Inputs (960 points/block) • 118
 Binary Output Command Examples • 45
 Binary Outputs • 35, 40
 Binary Outputs (960 points/block) • 118
 Block 9958 or 258 – PLC Binary Input Event
 • 85
 Block 9959 or 259 – PLC Analog Input Event
 • 86
 Block 9970 or 270 – Set PLC Time Using
 Module Time • 88
 Block 9971 or 271 – Set Module's Time
 Using PLC Time • 89
 Block 9998 or 255 – Warm Boot Module • 89
 Block 9999 or 253 – Cold Boot Module • 89

Block Assignments • 118
 Block Data Transfer Interface • 100

C

Cable Connections • 111
 CD Idle Time • 30, 39
 CD Random Time • 30, 39
 CD Time Before Receive • 30, 39
 Class 1 Unsol Resp Min • 32
 Class 2 Unsol Resp Min • 32
 Class 3 Unsol Resp Min • 33
 Clearing a Fault Condition • 72
 Clearing the Error List • 63
 Cmd Function • 43
 Collision Avoidance • 30, 38
 Collision Avoidance (DNP modules only) •
 117
 Command Control Blocks • 85
 Command Error Codes • 70, 138
 Command List • 47
 Configuration File • 26
 Configuring RSLinx • 17
 Connect Timeout • 29
 Connect your PC to the Module • 19
 Connect your PC to the Processor • 15
 Controlling Law and Severability • 167
 Counters • 35, 40
 Counters (30 points/block) • 119

D

Data Flow Between MVI71-DNP Module and
 PLC Processor • 91
 Data Link Confirm Mode • 32
 Data Link Confirm Tout • 32
 Data Link Max Retry • 32
 Data Object • 43
 Data Requirements • 95
 Data Variation • 43
 DB9 to RJ45 Adaptor (Cable 14) • 116
 Designing the system • 94
 Device Address • 43
 Device Profile • 141
 Diagnostics and Troubleshooting • 9, 59
 Disabling the RSLinx Driver for the Com Port
 on the PC • 61, 111
 DISCLAIMER OF ALL OTHER
 WARRANTIES • 165
 DISCLAIMER REGARDING HIGH RISK
 ACTIVITIES • 165
 DNP Analog Input Data • 107
 DNP Analog Output Data • 109
 DNP Configuration Forms • 121
 DNP Counter Data • 105
 DNP Database View Menu • 64, 67
 DNP DB Address • 43, 49
 DNP Digital Input Data • 102
 DNP Digital Output Data • 104
 DNP Functionality Review • 94

DNP Port Configuration Errors • 137
DNP User File Configuration • 121
Double Deadband • 31
Download the Sample Program to the
Processor • 16

E

Error Status Table • 132
Event Messages to PLC • 39
Event Size Computation • 140

F

Features and Benefits • 76
First Character Delay • 29
Float Class • 31
Float Deadband • 31
Float Inputs • 35
Float Outputs • 36
Function • 49
Functional Overview • 9, 78
Functional Specifications • 77

G

General Command Errors • 138
General Concepts • 78
General Specifications • 76
Guide to the MVI71-DNP User Manual • 9

H

Hardware Specifications • 76
How to Contact Us
Sales and Support • 160

I

Idle Timeout • 30
IED Analog Input Data • 110
IED Analog Output Data • 110
IED Binary Input Data • 110
IED Binary Output Data • 110
IED Counter Data • 110
IED DB Address • 43, 49
Initialize DNP Database • 33
Initialize IED Database • 39
Install the Module in the Rack • 13
Installing and Configuring the Module • 9, 21
Intellectual Property • 166
Internal ID • 39
Internal Slave ID • 28

K

Keystrokes • 60

L

Ladder Logic • 57
LED Status Indicators • 72
LIMITATION OF REMEDIES** • 165
LIMITED WARRANTY • 163

M

Main Logic Loop • 79
Main Menu • 62
Master Command Error List Menu • 71
Master Command List Menu • 70
Master Driver Mode • 93
Master Unit Device Profile Object Subset •
150
Min Response Delay • 38
Minimum Response Delay • 29
Modem • 29
Module Data • 23
Module DNP Protocol Operation • 82
Module Error Codes • 136
Module Name • 27
Module Power Up and Configuration • 78
Moving Back Through 5 Pages of Registers •
68
MVI71-DNP Communication Module
Configuration • 124

N

Navigation • 60
No Other Warranties • 166
Node Address • 43
Normal Data Transfer • 84

O

Object • 48
Opening the Class Assignment Menu • 64
Opening the Command Error List Menu • 65
Opening the Command List Menu • 65
Opening the DNP Database View Menu • 64

P

Package Contents • 12
Phone Number • 30
PLC Analog Inputs • 34
PLC Analog Outputs • 35
PLC Binary Inputs • 34
PLC Binary Outputs • 35
PLC Counters • 35
PLC Float Inputs • 35
PLC Float Outputs • 36
PLC Program Block Assignments vs. File
Offset • 118
Please Read This Notice • 2
Point Count • 43, 49

Poll Interval • 44, 49
 Procedures for Return of Units Out of
 Warranty • 162
 Procedures for Return of Units Under
 Warranty • 161
 Product Specifications • 9, 75
 ProSoft Technology, Inc., Support, Service &
 Warranty • 9, 159
 Purchasing Warranty Extension • 163

R

Read Block • 84
 Reading Status Data From the Module • 9,
 59
 Receiving the Configuration File • 64
 Redial Delay Time • 29
 Redial Random Delay • 30
 Redisplaying the Current Page • 66, 70, 71
 Reference • 9, 75
 Required Hardware • 60
 Required Software • 61
 Return Material Authorization (RMA) Policies
 and Conditions • 161
 Returning to the Main Menu • 66, 70, 71
 RS-232 • 113
 Modem Connection • 114
 Null Modem Connection
 (Hardware Handshaking) • 114
 Null Modem Connection (No
 Hardware Handshaking) • 115
 RS-232 Configuration/Debug Port • 111
 RS-422 • 115
 RS-485 • 116
 RS-485 and RS-422 Tip • 116
 RTS Off • 29, 38
 RTS On • 29, 38

S

Select/Operate Arm Time • 31
 Sending the Configuration File • 64
 Setting Jumpers • 13
 Setting the Debug Level • 62
 Side Connect Interface • 99
 Side-Connect Backplane Data Transfer • 90
 Side-Connect Interface File List • 90
 Skipping 500 Registers of Data • 68
 Slave Address • 48
 Slave Driver • 91
 Slave List • 46
 Slave Port Communication Errors • 136
 Slave Unit Device Profile Object Subset •
 142
 Solicited Messaging • 83
 Start Here • 9, 11
 Status Data • 23
 System Configuration Errors • 137
 System Design Considerations • 94

System Requirements • 11

T

The Class Assignment Menu • 65
 The Configuration/Debug Menu • 59
 Time Limit for Bringing Suit • 165
 Time Sync Before Events • 33
 Transferring the Configuration File to the
 Module • 52
 Transferring the Configuration File to Your
 PC • 50
 Trip/Close • 105
 Troubleshooting • 73
 Type • 38

U

Un-repairable Units • 162
 Unsol Resp Delay • 33
 Unsolicited Messaging • 82
 Unsolicited Response • 32
 Uploading and Downloading the
 Configuration File • 50, 64
 UResp Master Address • 33
 UResp Retry Count • 33
 User Data • 25
 Using the Configuration/Debug Port • 61

V

Variation • 48
 Viewing Analog Inputs • 66
 Viewing Binary Inputs • 66
 Viewing Block Transfer Statistics • 64
 Viewing COM States • 63
 Viewing Comm Stats • 63
 Viewing Data in ASCII (Text) Format • 69
 Viewing Data in Decimal Format • 68
 Viewing Data in Double Word Decimal
 Format • 69
 Viewing Data in Floating Point Format • 69
 Viewing Data in Hexadecimal Format • 68
 Viewing Data Type Databases • 68
 Viewing DNP Analog Inputs • 69
 Viewing DNP Analog Outputs • 69
 Viewing DNP Binary Inputs • 69
 Viewing DNP Binary Outputs • 69
 Viewing DNP Counters • 69
 Viewing DNP Float Inputs • 69
 Viewing DNP Float Outputs • 69
 Viewing DNP Frozen Counters • 69
 Viewing DNP Set Up & Pointers • 63
 Viewing Double Inputs • 66
 Viewing Float Inputs • 66
 Viewing Master Port Slave Setup • 64
 Viewing Operating Parameters • 63
 Viewing the Error List • 63
 Viewing the Next 100 Registers of Data • 68
 Viewing the Next 20 Commands • 71

Viewing the Next 50 Commands • 70
Viewing the Next Page of Commands • 70,
71
Viewing the Next Page of Data • 66
Viewing the Previous 100 Registers of Data •
68
Viewing the Previous 20 Commands • 71
Viewing the Previous 50 Commands • 70
Viewing the Previous Page of Commands •
70, 71
Viewing the Previous Page of Data • 66
Viewing Version Information • 64

W

Warm Booting the Module • 63
What Is Covered By This Warranty • 163
What Is Not Covered By This Warranty • 164
Write Block • 85
Write Time Interval • 31

Y

Your Feedback Please • 3